

**AAO**

**Integrating the Healthcare Enterprise**



**IHE Eye Care Technical Framework  
Year 3: 2008**

**Volume I  
Integration Profiles**

Revision 3.5

**Final Text Version**

Publication Date: January 31, 2009

Copyright © 2009: IHE International

## Contents

1	Introduction.....	5
1.1	Overview of Technical Framework.....	5
1.2	Overview of Volume I.....	5
1.3	Audience.....	6
1.4	Relationship to Standards.....	6
1.5	Relationship to Real-world Architectures.....	7
1.6	Conventions.....	7
1.6.1	Actor and Transaction Diagrams and Tables.....	7
1.6.2	Process Flow Diagrams.....	8
1.6.3	Normative versus informative contents of the Technical Framework.....	8
1.6.4	Technical Framework Referencing.....	8
1.6.5	Transaction Referencing.....	9
1.7	IHE Eye Care Current Year Scope.....	9
1.8	Comments.....	9
1.9	Copyright Permission.....	10
1.10	IHE Technical Framework Development and Maintenance Process.....	10
1.10.1	New Development – Extending the Existing Technical Framework.....	11
1.10.2	Maintenance of existing Technical Framework content.....	12
1.10.3	Use of Technical Framework.....	13
2	Integration Profiles.....	14
2.1	Dependencies between Integration Profiles.....	14
2.2	Integration Profiles Overview.....	16
2.2.1	Eye Care Workflow (EYECARE).....	17
2.2.2	Eye Care Charge Posting (EC-CHG).....	18
2.2.3	Eye Care Evidence Documents (ECED).....	18
2.2.4	Eye Care Displayable Report (ECDR).....	18
2.3	Actor Descriptions.....	19
2.4	Transaction Descriptions.....	20
2.5	Product Implementations.....	23
3	EYE CARE Workflow (EYECARE).....	25
3.1	Actors/Transactions.....	26
3.2	Eye Care Workflow Integration Profile Options.....	28
3.2.1	Acquisition Modalities Storage Options.....	30
3.2.2	Ophthalmic Photography Relative Image Position Coding Option.....	30
3.2.3	Radiological Studies of the Eye.....	31
3.2.4	Stereo Relationship Option.....	32
3.3	Eye Care Workflow Process Flow.....	32
3.3.1	Extension to Query Modality Worklist for Eye Care [EYECARE-1].....	35
3.4	Eye Care Workflow Use Cases.....	36
3.4.1	Workflow Example with Manual Procedure Order.....	36
3.4.2	Workflow Where the Procedure Ordered is an Automatic Eye Care Order.....	37

3.5	Workflow Concepts in Practice.....	38
3.6	Workflow Use Cases .....	40
3.6.1	Case E1: Patient Registered at ADT and Procedure Ordered at the Order Placer	41
3.6.2	Case E2: Patient Registered at ADT and Procedure Ordered at DSS/OF .....	42
3.6.3	Case E3: Unidentified Patient Registered at ADT but Completed at Modality Prior to Order .....	43
3.6.4	Case E4: Unidentified Patient Assigned Temporary Departmental ID and Scheduled at DSS/Order Filler.....	45
3.6.5	Case E5: Image Acquisition Completed Without Scheduling at Department System Scheduler/Order Filler .....	47
3.6.6	Case E6: Patient Information Reconciliation During Image Acquisition.....	49
3.6.7	Case E7: Cancel Procedure.....	51
4	Eye Care Charge Posting (EC-CHG) .....	52
4.1	Actor/Transactions .....	52
4.2	Eye Care Charge Posting Integration Profile Options.....	54
4.3	Eye Care Charge Posting Process Flow .....	55
4.3.1	Use Cases .....	56
4.3.2	Eye Care Uses Cases for Technical Billing (Procedure Billing) .....	56
4.4	Data Model for Eye Care Charge Posting .....	57
4.4.1	Model of the Real World .....	57
5	Eye Care Evidence Documents (ECED) .....	59
5.1	Actors/Transactions .....	59
5.2	Evidence Documents Profile – EYE CARE Options .....	61
5.3	Eye Care Evidence Document Process Flow .....	61
5.4	Eye Care Evidence Documents Use Cases.....	62
5.4.1	Eye Care Evidence Documents Being Created by Acquisition Modality .....	62
5.4.2	Eye Care Evidence Documents Being Created by Workstations .....	63
6	Eye Care Displayable Report (ECCR) .....	64
6.1	Actors/Transactions .....	64
6.2	Eye Care Displayable Report Integration Profile Options .....	65
6.3	Eye Care Displayable Report Use Case .....	65
6.3.1	Typical Displayable Report Example .....	66

## Foreword

Integrating the Healthcare Enterprise (IHE) is an initiative designed to stimulate the integration of the information systems that support modern healthcare institutions. Its fundamental objective is to ensure that in the care of patients all required information for medical decisions is both correct and available to healthcare professionals. The IHE initiative is both a process and a forum for encouraging integration efforts. It defines a technical framework for the implementation of established messaging standards to achieve specific clinical goals. It includes a rigorous testing process for the implementation of this framework. And it organizes educational sessions and exhibits at major meetings of medical professionals to demonstrate the benefits of this framework and encourage its adoption by industry and users.

The approach employed in the IHE initiative is not to define new integration standards, but rather to support the use of existing standards, HL7, DICOM, IETF, and others, as appropriate in their respective domains in an integrated manner, defining configuration choices when necessary. When clarifications or extensions to existing standards are necessary, IHE refers recommendations to the relevant standards bodies.

This initiative has numerous sponsors and supporting organizations in different medical specialty domains and geographical regions. In North America the primary sponsors are the American Academy of Ophthalmology (AAO), the Healthcare Information and Management Systems Society (HIMSS) and the Radiological Society of North America (RSNA). IHE Canada has also been formed. IHE Europe (IHE-EUR) is supported by a large coalition of organizations including the European Society of Cardiology (ESC), European Association of Radiology (EAR) and European Congress of Radiologists (ECR), the Coordination Committee of the Radiological and Electromedical Industries (COCIR), Deutsche Röntgengesellschaft (DRG), the EuroPACS Association, Groupement pour la Modernisation du Système d'Information Hospitalier (GMSIH), Société Française de Radiologie (SFR), and Società Italiana di Radiologia Medica (SIRM). In Japan IHE-J is sponsored by the Ministry of Economy, Trade, and Industry (METI); the Ministry of Health, Labor, and Welfare; and MEDIS-DC; cooperating organizations include the Japan Industries Association of Radiological Systems (JIRA), the Japan Association of Healthcare Information Systems Industry (JAHIS), Japan Radiological Society (JRS), Japan Society of Radiological Technology (JSRT), and the Japan Association of Medical Informatics (JAMI). Other organizations representing healthcare professionals are invited to join in the expansion of the IHE process across disciplinary and geographic boundaries.

The IHE Technical Frameworks for the various domains (IT Infrastructure, Cardiology, Laboratory, Radiology, Eye Care, etc.) define specific implementations of established standards to achieve integration goals that promote appropriate sharing of medical information to support optimal patient care. They are expanded annually, after a period of public review, and maintained regularly through the identification and correction of errors. The current version for these Technical Frameworks may be found at [www.aao.org](http://www.aao.org), or [www.ihe.net](http://www.ihe.net).

The IHE Technical Frameworks identify a subset of the functional components of the healthcare enterprise, called IHE Actors, and specify their interactions in terms of a set of coordinated, standards-based transactions. They describe this body of transactions in progressively greater depth. This volume I provides a high-level view of IHE functionality, showing the transactions organized into functional units called Integration Profiles that highlight their capacity to address specific clinical needs. The subsequent volumes provide detailed technical descriptions of each IHE transaction.

**Comments arising from Final Text may be submitted to:**

**<http://forums.rsna.org> under the “*Integrating the Healthcare Enterprise*”  
forum**

**Select the “*IHE Eye Care Technical Framework Volume 1 version 3.5 Final Text*” sub-forum.**

## 1 Introduction

### 1.1 Overview of Technical Framework

This document, the IHE Eye Care Technical Framework (IHE EYECARE-TF), defines specific implementations of established standards to achieve integration goals for Eye Care. Such integration promotes appropriate sharing of medical information to support optimal patient care.

The EYECARE-TF is expanded annually, after a period of public review, and maintained regularly through the identification and correction of errors. The latest version of the document is always available via the Internet at [www.aao.org](http://www.aao.org).

The EYECARE-TF identifies a subset of the functional components of the healthcare enterprise, called IHE actors, and specifies their interactions in terms of a set of coordinated, standards-based transactions. It describes this body of transactions in progressively greater depth. The present Volume I provides a high-level view of IHE functionality, showing the transactions organized into functional units called Integration Profiles that highlight their capacity to address specific clinical needs. Volume II provides detailed technical descriptions of each eye care specific IHE transaction.

The EYECARE-TF is part of a related set of IHE Technical Frameworks, inclusive of the following domain-specific documents:

- IHE Eye Care Technical Framework
- IHE Cardiology Technical Framework
- IHE IT Infrastructure Technical Framework
- IHE Radiology Technical Framework
- IHE Laboratory Technical Framework
- Others.....

The IHE Eye Care Integration Profiles rely heavily on, and reference, the transactions defined in those other IHE Technical Framework documents. For the conventions on referencing other frameworks, see Section 1.6.4 within this volume.

### 1.2 Overview of Volume I

The remainder of section 1 further describes the general nature, purpose and function of the Technical Framework. Section 2 introduces the concept of IHE Integration Profiles that make up the Technical Framework.

Section 3 and the subsequent sections of this volume provide detailed documentation on each Integration Profile, including the clinical problem it is intended to address and the IHE Actors and Transactions it comprises.

The appendices following the main body of the document provide detailed discussion of specific issues related to the Integration Profiles and a glossary of terms and acronyms used.

### **1.3 Audience**

The intended audience of this document is:

- Healthcare providers interested in the technical aspects of integrating healthcare information systems
- Technical staff of vendors participating in the IHE initiative
- IT departments of healthcare institutions
- Experts involved in standards development

### **1.4 Relationship to Standards**

The IHE Technical Framework identifies functional components of a distributed healthcare environment (referred to as IHE Actors), solely from the point of view of their interactions in the healthcare enterprise. At its current level of development, it defines a coordinated set of transactions based on the HL7, DICOM, and various Web standards. As the scope of the IHE initiative expands, transactions based on other standards will be included as required.

In some cases, IHE recommends selection of specific options supported by these standards; however, IHE does not introduce technical choices that contradict conformance to these standards. If errors in or extensions to existing standards are identified, IHE's policy is to report them to the appropriate standards bodies for resolution within their conformance and standards evolution strategy.

IHE is therefore an implementation framework, not a standard. Referencing IHE as a standard is inappropriate. Conformance claims by product must still be made in direct reference to specific standards. In addition, vendors that have implemented IHE integration capabilities shall use an IHE Integration Statement to describe the conformance of their product to the specifications in the IHE Technical Framework. The purpose of an IHE Integration Statement is to communicate in a uniform manner to the users of the corresponding product the IHE capabilities it has been designed to support. Vendors publishing IHE Integration Statements accept full responsibility for their content. By comparing the IHE Integration Statements from different implementations, a user familiar with the IHE concepts of Actors and Integration Profiles should be able to determine whether and to what extent communications might be supported between products. See Appendix C for the format of such IHE Integration Statements. IHE encourages implementers to ensure that products implemented in accordance with the IHE Technical Framework also meet the full requirements of the standards underlying IHE, allowing the products to interact, although possibly at a lower level of integration, with products that have been implemented in conformance with those standards, but not in full accordance with the IHE Technical Framework.

## 1.5 Relationship to Real-world Architectures

The IHE Actors and transactions described in the IHE Technical Framework are abstractions of the real-world healthcare information system environment. While some of the transactions are traditionally performed by specific product categories (e.g. Hospital Information System (HIS), Electronic Health Record, Practice Management Systems, Image Management Systems, or acquisition modalities), the IHE Technical Framework intentionally avoids associating functions or actors with such product categories. For each actor, the IHE Technical Framework defines only those functions associated with integrating information systems. The IHE definition of an actor should therefore not be taken as the complete definition of any product that might implement it, nor should the framework itself be taken to comprehensively describe the architecture of a healthcare information system.

The reason for defining actors and transactions is to provide a basis for defining the interactions among functional components of the healthcare information system environment. In situations where a single physical product implements multiple functions, only the interfaces between the product and external functions in the environment are considered to be significant by the IHE initiative. Therefore, the IHE initiative takes no position as to the relative merits of an integrated environment based on a single, all-encompassing information system versus one based on multiple systems that together achieve the same end. To illustrate most dramatically the possibilities of the IHE Technical Framework, however, the IHE demonstrations emphasize the integration of multiple vendors' systems based on the IHE Technical Framework.

## 1.6 Conventions

This document has adopted the following conventions for representing the framework concepts and specifying how the standards upon which the IHE Technical Framework is based should be applied.

### 1.6.1 Actor and Transaction Diagrams and Tables

Each integration profile is a representation of a real-world capability that is supported by a set of actors that interact through transactions. Actors are information systems or components of information systems that produce, manage, or act on categories of information required by operational activities in the enterprise. Transactions are interactions between actors that transfer the required information through standards-based messages.

The tables of Actors and Transactions given in sections 3 – 5 indicate which Transactions each Actor in a given profile must support.

In some cases, a profile is dependent on a pre-requisite profile in order to function properly and be useful. This version of Eye Care has not used the concept of a pre-requisite profile.

## 1.6.2 Process Flow Diagrams

The descriptions of Integration Profiles that follow include Process Flow Diagrams that illustrate how the profile functions as a sequence of transactions between relevant actors.

These diagrams are intended to provide a “big picture” so the transactions can be seen in the context of the overall workflow. Certain transactions and activities not defined in detail by IHE are shown in these diagrams in *italics* to provide additional context on where the relevant IHE transactions fit into the broader scheme of healthcare information systems.

These diagrams are not intended to present the only possible scenario. Often other actor groupings are possible, and complementary transactions from other profiles may be interspersed.

In some cases the sequence of transactions may be flexible. Where this is the case there will generally be a note pointing out the possibility of variations.

The convention used in these diagrams is that the arrow on the line for the transaction points from the initiator of the transaction to the destination.

## 1.6.3 Normative versus informative contents of the Technical Framework

Most parts of the Technical Framework describe required or optional characteristics of Integration Profiles, Actors and Transactions: these are normative. For a better understanding of the text, there also exist illustrating parts in the Technical Framework that are informative and non-normative.

According to IETF RFC 2119, certain words indicate whether a specific content of the Technical Framework is normative: either required (e.g. “must”, “required”, “shall”) or optional (e.g. “may”, “recommended”). Informative content does not contain these key words.

## 1.6.4 Technical Framework Referencing

When references are made to a section within the same Technical Framework volume, a section number is used by itself. When references are made to other volumes or to a Technical Framework in another domain, the following format is used:

<domain designator> TF-<volume number>: <section number>, where

<domain designator> is a short designator for the IHE domain (ITI = IT Infrastructure, RAD = Radiology, CARD = Cardiology, LAB = Laboratory, EYECARE = Eye Care)

<volume number> is the applicable volume within the given Technical Framework (e.g., 1, 2, 3), and

<section number> is the applicable section number.

For example: ITI TF-1: 3.1 refers to section 3.1 in volume 1 of the IHE IT Infrastructure Technical Framework, RAD TF-3: 4.33 refers to section 4.33 in volume 3 of the IHE Radiology Technical Framework.

### 1.6.5 Transaction Referencing

When references are made to a Transaction, the following format is used:

<domain designator>-<transaction number>, where

<domain designator> is a short designator for the IHE domain (ITI = IT Infrastructure, RAD = Radiology, CARD = Cardiology, LAB = Laboratory, EYECARE = Eye Care)

<transaction number> is the applicable transaction number as specified in the Technical Framework for that domain.

Transactions may also be referenced by name, but only after that transaction name has been identified with its domain and transaction number within that section of the document.

## 1.7 IHE Eye Care Current Year Scope

This document refers to Year 3 of the IHE Eye Care initiative. It will be the basis for the testing and exhibition process associated with the AAO annual meetings and other demonstrations. The current IHE Eye Care Technical Framework addresses the following primary features:

- The Eye Care Workflow Integration Profile (EYE CARE) describes mechanisms to manage and distribute the workflow within the eye clinic across the several types of equipment in a synchronized manner.
- The Eye Care Charge Posting Integration Profile (EC-CHG), included by reference to its definition in the Radiology Technical Framework with further eye care specific options describes the mechanisms to collect and post timely billable claims related to Eye Care procedural data.
- The Eye Care Evidence Documents Integration Profile (ECED), based upon the Evidence Documents (ED) definition in the Radiology Technical Framework with further eye care specific options, describes management of observations, measurements, and peri-procedural results (i.e., evidence documents).
- The Eye Care Displayable Report Integration Profile (ECDR) specifies transactions supporting the creation, query/retrieve and reading of display –ready eye care reports. The ECDR Profile allows use of the DICOM Encapsulated Document IOD, which has emerged as a ubiquitous means of encoding documents ready for presentation.

## 1.8 Comments

The AAO welcomes comments on this document and the IHE initiative. They should be directed to the discussion server at <http://forums.rsna.org/> or to:

Flora Lum, M.D.

Policy Director, Quality of Care and Knowledge Base Development

American Academy of Ophthalmology

e-mail: [flum@ao.org](mailto:flum@ao.org)

## **1.9 Copyright Permission**

Health Level Seven, Inc. has granted permission to the IHE to reproduce tables from the HL7 standard. The HL7 tables in this document are copyrighted by Health Level Seven, Inc. All rights reserved.

The National Electrical Manufacturers Association (NEMA) has granted permission to the IHE to incorporate portions of the DICOM standard.

Material drawn from these documents is credited where used.

## **1.10 IHE Technical Framework Development and Maintenance Process**

The Technical Framework is continuously extended and maintained by the IHE Eye Care Technical Committee, in cooperation with the other domain-specific Technical Committees. The Development and Maintenance Process of the Framework follows a number of principles to ensure stability of the specification both vendors and users may rely upon in specifying, developing and acquiring IHE compatible products.

The process is intended to address the need for extensions, clarifications and corrections while maintaining backward compatibility of framework definitions as to support implementations claiming conformance to any previously defined Integration Profile and its Actors.

To maintain stability of the IHE Technical Framework, modifications occur in a regular annual cycle (Figure 1.10-1) according to one of two controlled paths: new development, and maintenance.

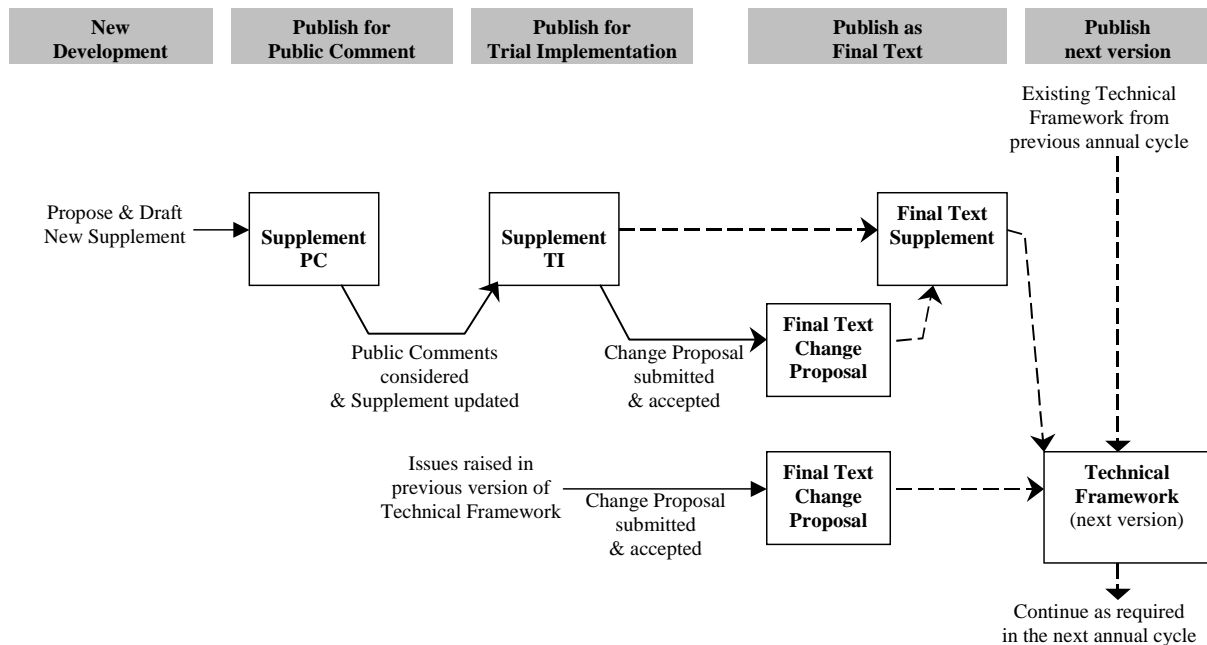

**Figure 1.10-1.** The figure shows the process of developing and maintaining the Technical Framework during an annual cycle. Dashed arrows indicate the assembly (merging) of text.

### 1.10.1 New Development – Extending the Existing Technical Framework

Each year, new functionality to be developed is identified by the IHE Eye Care Planning Committee. The Technical Committee performs the necessary analysis and design work and generates new text for the Technical Framework.

Generally, new functionality is published in the form of a Supplement. The scope of a Supplement is to make one of the following additions to the Technical Framework:

- A new Integration Profile, usually including the introduction of new Actors and Transactions.
- New Actors in an existing Integration Profile: These may be either Actors previously defined elsewhere in the Technical Framework, or new ones not yet defined. Transactions identifying the new actors responsibilities in this profile are identified or defined and may be designated as required or optional. To avoid causing compatibility problems for systems that have already implemented that profile, no new required Transactions are added for existing Actors in the profile.
- New Options in an existing Integration Profile: These usually add optional Transactions for existing actors in the profiles, or add optional features within existing Transactions.
- Major conceptual changes: They do not change the behavior of existing Integration Profiles but may imply changes or additions to Actors or Transactions in the future.

The publication process consists of certain phases and is clearly indicated on each document.

First, the text is published for **Public Comment** (with a “PC” designation). During the Public Comment period (typically 30 days), the text and a comment submission facility are available on the IHE Website. Following this period, the Technical Committee will review the comments.

Updated text of Supplements is then published for **Trial Implementation** (with a “TI” designation), based on the modifications resulting from the comments received.

IHE provides a process for vendors to test their implementation of the Trial Implementation specifications of IHE Actors and Integration Profiles. The IHE testing process, culminating in a multi-party interactive testing event called the Connect-a-thon, provides vendors with valuable feedback and provides a baseline indication of the conformance of their implementations. It also serves as a validation of the technical approach of the Trial Implementation specifications.

After trial implementations have been judged to have sufficiently exercised the new functionality (e.g., due to experience from the Connect-a-thon), and the text is considered sufficiently stable, the new text will be published as **Final Text** (with a “FT” designation).

Final Text Supplements will be merged at the end of the annual development cycle with the current version of the Technical Framework resulting in a new version of the Technical Framework with an increased version number.

### 1.10.2 Maintenance of existing Technical Framework content

Despite the best efforts of the Technical Committee, a published current version of the Technical Framework or Trial Implementation documents may contain text that is incorrect, incomplete or unclear. Such issues are handled as Change Proposals and cover:

- Corrections: technical issues causing non-interoperability of implementations are fixed without introducing changes in functionality of a stable Integration Profile.
- Clarifications: text that can be misunderstood or is ambiguous is made easier to understand or disambiguated, without introducing any technical changes.

The publication process is the same for both Corrections and Clarifications, and addresses both changes to Trial Implementations and changes to a current version of the Technical Framework.

A **Submitted Change Proposal** results from issues raised by users, vendors or Technical Committee members, e.g. from experiences with Trial Implementation or Final Text Integration Profiles or at a Connect-a-thon. The resulting Change Proposal document should explicitly state:

- the parts of the Technical Framework requested to be changed,
- a problem description,
- a rationale why the change is considered necessary,
- and a solution or approach to the problem.

The Technical Committee regularly considers Change Proposals which are then either accepted or rejected.

A **Rejected Change Proposal** is published with a rationale from the Technical Committee explaining why the change is not appropriate.

An **Accepted Change Proposal** is assigned to a member of the Technical Committee as a work item for further investigation with the goal to produce adequate clarifications or corrections. The resulting text will again be reviewed by the Technical Committee before being approved.

Once approved, a **Final Text Change Proposal** is published by the Technical Committee, and then is to be considered as effective. It will be merged into the next version of the Technical Framework at the end of the annual development cycle. Submitting a Change Proposal to a Final Text Change Proposal or a Final Text Supplement is not possible.

### 1.10.3 Use of Technical Framework

The current version of the Technical Framework is considered the primary reference document. Final Text Supplements and Final Text Change Proposals from the current annual cycle complement this document. Past Final Text documents are retained to provide convenient summaries of differences to prior versions of the Technical Framework or Trial Implementation versions of Supplements.

During the annual development and maintenance cycle, it is recommended to use Technical Framework documents for implementations as follows:

- **Product Implementations**  
Products implemented based on Trial Implementation text are expected to review the subsequent Final Text and update their products as necessary. Further, it is expected that vendors will monitor Final Text Change Proposals and make any corrections relevant to their product in a timely fashion.
- **Connect-a-thon Implementations**  
Testing at the Connect-a-thon will be based on the current version of the Technical Framework for the appropriate IHE Domain, plus any relevant Supplements for Trial Implementation and Final Text Change Proposals.

## 2 Integration Profiles

IHE Eye Care Integration Profiles, depicted in Figure 2-1, offer a common language that healthcare professionals and vendors may use in communicating requirements for the integration of products. Integration Profiles describe real-world scenarios or specific sets of capabilities of integrated systems. An Integration Profile applies to a specified set of actors and for each actor specifies the transactions necessary to support those capabilities.

Integration Profiles provide a convenient way for both users and vendors to reference a subset of the functionality detailed in the IHE Technical Framework. They enable users and vendors to be more specific than simply requesting or promising overall IHE support, without laborious restatement of the details regarding IHE actors and transactions defined by the IHE Technical Framework.

### 2.1 Dependencies between Integration Profiles

In general, IHE Integration Profiles do not operate independently. Objects that serve as useful input to one profile may have been produced as a result of implementing another profile.

Figure 2-1 provides a graphical view of the dependencies between Integration Profiles. The arrows in the diagram point from the dependent profile to the profile(s) on which it relies. The solid arrow indicates an implementation dependency – the actors of the dependent profile must implement the supporting profile. The open arrows indicate a definitional dependency – the transactions of the dependent profile are based on the transactions of the supporting profile; this is for information purposes only, since the supporting profile is not itself used, only some subset of it.

Note especially that the supporting profiles come from other IHE domains.

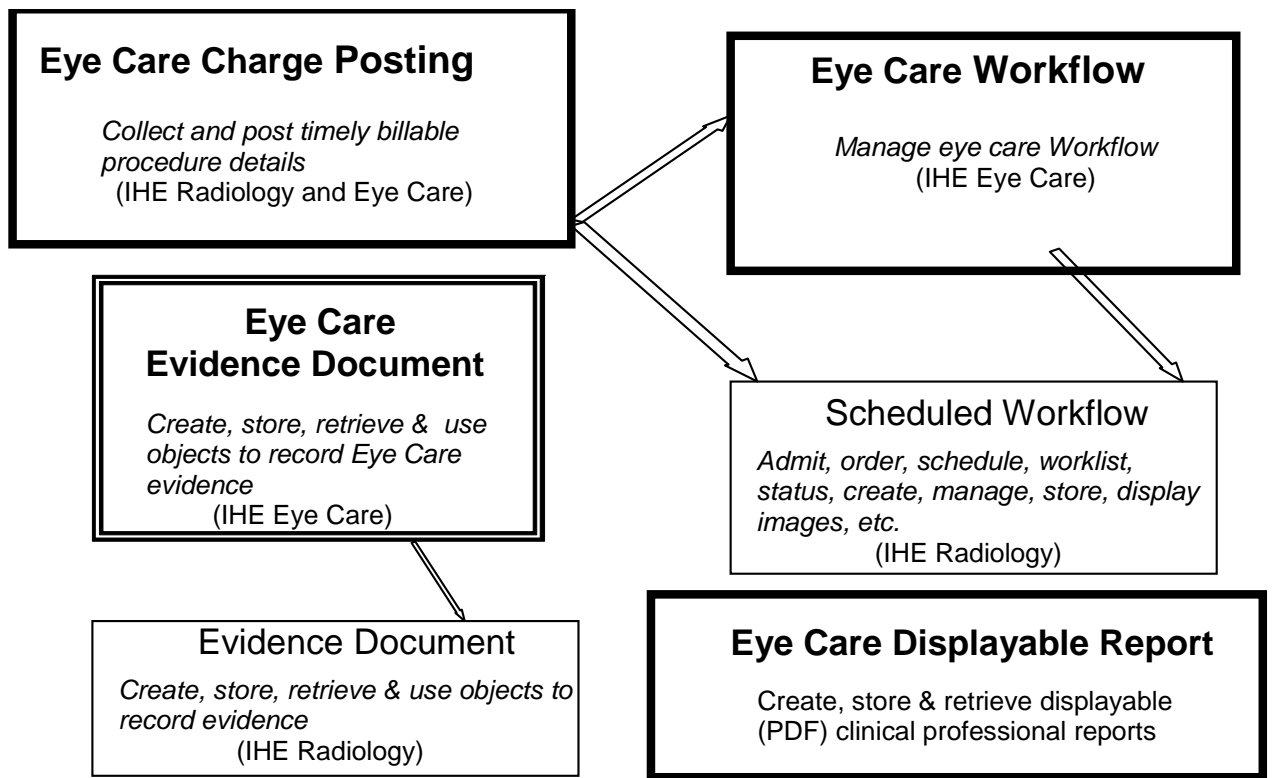

**Figure 2-1. IHE Eye Care Integration Profiles and Dependencies**

Table 2-1 defines the required dependencies between the Integration Profiles in a tabular form.

There are of course other useful synergies that occur when different combinations of profiles are implemented, but those are not described in the table below. For instance, actors of the various Eye Care profiles may implement profiles of the IT Infrastructure domain for user or node authentication, audit trails, patient identifier cross-referencing, etc.

**Table 2-1. Eye Care Integration Profiles Dependencies**

Integration Profile	Depends on	Dependency Type	Comments
Eye Care Workflow	RAD-TF Scheduled Workflow	This profiles uses definitions from those specified	

Integration Profile	Depends on	Dependency Type	Comments
Eye Care Charge Posting	RAD-TF Charge Posting EYECARE-TF Eye Care Workflow RAD-TF Scheduled Workflow	This profiles uses definitions from those specified	This profiles uses the Charge Posting profile defined in Radiology to accomplish the same feature in Eye Care
Eye Care Evidence Document	RAD-TF Evidence Document	This profiles uses definitions from those specified	This profile uses the Evidence Document Radiology profile but specializes it for Eye Care
Eye Care Displayable Report	None	None	None

Vendor products support an Integration Profile by implementing the appropriate actor-transactions as outlined in the Integration Profile in sections 3 through 5. A product may implement more than one actor and more than one Integration Profile.

An actor must implement all required transactions in the pre-requisite profiles in addition to those in the desired profile.

Actors (see section 2.2) are information systems or components of information systems that produce, manage, or act on information associated with operational activities in the enterprise.

Transactions (see section 2.3) are interactions between actors that transfer the required information through standards-based messages.

## 2.2 Integration Profiles Overview

In this document, each IHE Integration Profile is defined by:

- The IHE Actors involved
- The specific set of IHE Transactions required for each IHE Actor.

These requirements are presented in the form of a table of transactions required for each actor supporting the Integration Profile. Actors supporting multiple Integration Profiles are required to support all the required transactions of each Integration Profile supported. When an Integration Profile depends upon another Integration Profile, all transactions required for the dependent Integration Profile have been included in the table.

Note that IHE Integration Profiles are not statements of conformance to standards, and IHE is not a certifying body. Users should continue to request that vendors provide statements of their

conformance to relevant standards, such as DICOM and HL7. Standards conformance is a prerequisite for vendors adopting IHE Integration Profiles.

Also note that there are critical needs for any successful integration project that IHE cannot address. Successfully integrating systems still requires a project plan that minimizes disruptions and describes fail-safe strategies, specific and mutually understood performance expectations, well-defined user interface requirements, clearly identified systems limitations, detailed cost objectives, plans for maintenance and support, etc.

The many workflow scenarios described in this document have the need to identify healthcare providers. The definition of healthcare provider varies greatly such as a provider of medical or health services and any other person or organization who furnishes, bills, or is paid for healthcare in the normal course of business. We are not attempting to define the term, however will use the term “healthcare providers”.

### **2.2.1 Eye Care Workflow (EYECARE)**

EYECARE addresses three workflow scenarios, standalone eye care clinics; large eye care groups and hospital-based eye care departments.

Note: We understand that others scenarios exist, i.e. Eye Care Referrals, Tele-medicine, etc. However, they are not being formally addressed and will be considered in future versions.

In Eye Care, patients present with a variety of symptoms and complaints, which may or may not result in the need for diagnostic imaging and testing. Some types of imaging and testing may be performed routinely, before patients are seen by a healthcare provider. Other types of imaging and testing may be performed only after a healthcare provider has determined the need for them while examining the patient. Thus orders may be placed either manually, or automatically. This requirement of flexibility is paramount.

The Eye Care Workflow Integration Profile establishes the continuity and integrity of basic patient and procedure data in the context of an eye care clinic and/or an integrated hospital workflow scenario. This profile deals specifically with consistent handling of patient identifiers and demographic data. This includes when specific procedure(s) have been manually ordered by a healthcare provider in addition to the scenario where an automatic eye care order has been placed. The automatic orders are created for procedures routinely performed on patients without a healthcare provider order and frequently prior to the patient being seen by a healthcare provider. Thus the purpose of the automatic order is not to provide legal authority for performing a procedure, but rather to provide data integrity. This profile specifies the scheduling and coordination of procedure data to a wide variety of diagnostic imaging and testing equipment, and its reliable storage in an image management system from where it is available to support subsequent workflow steps, such as reporting. It also provides the ability for the acquisition devices (such as diagnostic imaging, measuring, test equipment) to identify the actual procedure(s) that were performed. This enables further workflow steps such as automated billing for the procedure.

### **2.2.2 Eye Care Charge Posting (EC-CHG)**

The Eye Care Charge Posting Integration Profile specifies the exchange of information from department ordering systems to billing systems regarding charges associated with particular procedures. It also defines the communication between patient registration systems and billing systems about patient demographics, accounts, insurance, and guarantors. The Charge Posted Transaction contains all of the required procedure data to generate a claim. The procedure information is obtained from acquisition modalities via transactions from the *Eye Care Workflow Integration Profile*. The goal of including this transaction in the IHE Technical Framework is to standardize the Charge Posted Transaction to a billing system, thus reducing system interface installation time. Additionally, the Charge Posted Transaction reduces the need of the billing system to have knowledge of the eye care internals. The result is that the billing system will receive more complete, timely and accurate data.

Note: This version of the IHE EYECARE TF does not include professional reporting, therefore, has not used the roles of Report Creator and Evidence Creator. This will be addressed in the future and will most likely be part of Charge Posting.

### **2.2.3 Eye Care Evidence Documents (ECED)**

The Evidence Documents Profile defines ways for data recorded in the course of carrying out a procedure step, such as observations, measurements, and results (i.e., evidence documents), to be output by devices, such as acquisition systems and other workstations; to be stored and managed by archival systems; and to be retrieved and presented or used by display and reporting systems.

This allows detailed information, such as reconstructed or derived images, measurements, post processing results, etc. to be made available as input to the process of generating a clinical Report, either as additional evidence for the reporting healthcare provider, or in some cases for selected items in the Evidence Document to be included in the report.

A couple of examples include glaucoma progression analysis performed on visual field analyzers, or the retinal nerve fiber layer (RNFL) analysis performed on an ocular coherence tomography (OCT) device.

### **2.2.4 Eye Care Displayable Report (ECDR)**

The Displayable Reports Profile specifies transactions supporting the creation, query/retrieve, and reading of display-ready eye care reports. The ECDR Profile allows use of a DICOM Encapsulated Document, which has emerged as a ubiquitous means of encoding documents ready for presentation, including graphical content. Furthermore, the ECDR profile allows the reporting healthcare provider to control the “look” of the report, which is important for both clinical and business reasons.

Note: The types of Encapsulation documents supported are defined in EYECARE TF-2: 4.7, such as DICOM Encapsulated PDF SOP Class.

## 2.3 Actor Descriptions

Actors are information systems or components of information systems that produce, manage, or act on information associated with operational activities in the enterprise. The following are the actors defined by IHE and referenced throughout the rest of this document, as well as in other domain Technical Framework documents.

It is acknowledged that some of the terms used as modifiers for the actor names are not used consistently (e.g., Image Manager, which also manages non-image objects). At this point, the benefit in doing extensive renaming to gain consistency is outweighed by the risk of introducing significant confusion that would result from renaming many of the existing actors that are shared across multiple domains. Therefore the actor names will remain as defined below.

**Acquisition Modality** – A system that acquires and creates medical images while a patient is present. A modality may also create other evidence objects such as Grayscale Softcopy Presentation States for the consistent viewing of images or Evidence Documents containing measurements, etc. In eye care, modalities acquire diagnostic information such as images and/or evidence documents. Some examples of these may include photography, topography, refractive exams, corneal and retinal topography, visual fields, etc.

**ADT/Patient Registration** – A system responsible for adding and/or updating patient demographic and encounter information (Admission/Discharge/Transfer). In particular, it registers a new patient with the Order Placer and Department System. Some possible eye care examples include a Practice Management System (PMS) or a Hospital Information System (HIS).

**Charge Processor** – Receives the posted charges and serves as a component of the financial system (for instance a PMS or billing system).

**Department System Scheduler/Order Filler** – A department-based system that provides functions related to the management of orders received from external systems or through the department system's user interface. An eye care example of a department based system could be an Eye Care Electronic Health Record (EHR)).

**Evidence Creator** – A system that creates additional evidence objects such as derived images or measurements (Evidence Documents), and transmits them to an Image Archive (for instance, acquisition modalities, image displays, post processing systems, EHR, etc.).

**Image Archive** – A system that provides long-term storage of evidence objects such as images, presentation states, Key Image Notes and Evidence Documents.

**Image Display** – A system that offers browsing of patients' studies. In addition, it may support the retrieval and display of selected evidence objects including sets of images, presentation states, Key Image Notes, and/or Evidence Documents.

**Image Manager** – A system that provides functions related to safe storage and management of evidence objects. It supplies availability information for those objects to the Department System Scheduler.

**Order Placer** – A hospital or enterprise-wide system that generates orders for various departments and distributes those orders to the correct department (i.e. PMS, HIS, etc.).

**Performed Procedure Step Manager** – A system that re-distributes the Modality Performed Procedure Step information from the Acquisition Modality to the Department System Scheduler/Order Filler and Image Manager.

**Report Creator** – A system that generates and transmits clinical reports.

**Report Reader** – A system that can query/retrieve and view reports encoded as DICOM objects.

**Report Repository** – A departmental system that receives reports and stores them for long-term access.

**Note:** The above Eye Care examples are typical products that may perform these roles, but IHE does not dictate this and any product may choose to implement any role.

The following table shows which actors are used in which Integration Profiles.

**Table 2.3-1. Integration Profile Actors**

<b>Actor</b> \ <b>Integration Profile</b>	<b>EYE CARE Workflow</b>	<b>Eye Care Charge Posting</b>	<b>Eye Care Evidence Document</b>	<b>Eye Care Displayable Report</b>
Acquisition Modality	X	X	X	
ADT Patient Registration	X	X		
Charge Processor		X		
Department System Scheduler/Order Filler	X	X		
Evidence Creator	X		X	
Image Archive	X		X	
Image Display	X		X	
Image Manager	X		X	
Order Placer	X			
Performed Procedure Step Manager	X	X		
Report Creator				X
Report Reader				X
Report Repository				X

## 2.4 Transaction Descriptions

Transactions are interactions between actors that transfer the required information through standards-based messages. The following are the transactions defined by IHE and referenced

throughout the rest of this document. Those transactions specified in other domain Technical Framework documents are identified with the domain identifier and transaction number.

**Patient Registration** – The ADT system registers and/or admits a patient and forwards the information to other information systems. [RAD-1]

**Placer Order Management** – The Order Placer informs the Department System Scheduler/Order Filler of the initiation or cancellation of an order. The Placer/Filler Order Management transaction will sometimes be referred to as “-New” when a new order is being initiated, or as “-Cancel” when an existing order is canceled. [RAD-2]

**Filler Order Management** – The Department System Scheduler/Order Filler informs the Order Placer of the initiation, cancellation, or change in the status of an order. The Placer/Filler Order Management transaction will sometimes be referred to as “-New” when a new order is being initiated, or as “-Cancel” when an existing order is canceled. [RAD-3]

**Procedure Scheduled** – Schedule information is sent from the Department System Scheduler/Order Filler to the Image Manager. [RAD-4]

**Query Modality Worklist** – Based on a query entered at the Acquisition Modality, a modality worklist is generated listing all the items that satisfy the query. This list of Scheduled Procedure Steps with selected demographic information is returned to the Acquisition Modality [EYECARE-1, derived from RAD-5].

**Modality Procedure Step In Progress** – An Acquisition Modality notifies the Performed Procedure Step Manager of the start of a new Procedure Step and the PPS Manager informs the Department System Scheduler/Order Filler and Image Manager. [RAD-6]

**Modality Procedure Step Completed** – An Acquisition Modality notifies the Performed Procedure Step Manager of the completion of a Procedure Step and the PPS Manager informs the Department System Scheduler/Order Filler and Image Manager. [EYECARE-6, derived from RAD-7]

**Modality Images/Evidence Stored** – An Acquisition Modality sends acquired or generated images, waveforms, or other evidence documents to the Image Archive. [EYECARE-2, derived from RAD-8]

**Query Evidence Documents** – A user of Evidence Documents (i.e. Image Display, Evidence Creators, etc.) queries the Image Archive for a list of entries representing Evidence Documents. [EYECARE-4, derived from RAD-44]

**Retrieve Evidence Documents** – A user of Evidence Documents (Image Display, Evidence Creators, etc.) requests and retrieves an Evidence Document from the Image Archive. [RAD-44]

**Storage Commitment** – A requestor (Acquisition Modality) requests that the Image Manager confirm ownership for the specified DICOM objects (images, evidence documents, or any combination thereof) that the requestor stored in the Image Archive, thus allowing

the sender to delete those objects now owned by the Image Manager. [CARD-3, derived from RAD-10]

**Patient Update** – The ADT Patient Registration System informs the Order Placer and the Department System Scheduler/Order Filler of new information for a particular patient. The Department System Scheduler may then further inform the Image Manager. [RAD-12]

**Procedure Update** – The Department System Scheduler/Order Filler sends the Image Manager updated order or procedure information. [RAD-13]

**Query Images** – An Image Display queries the Image Archive for a list of entries representing images by patient, study, series, or instance. [EYECARE-5, derived from RAD-14]

**Retrieve Images** – An Image Display requests and retrieves a particular image or set of images from the Image Archive. [EYECARE-3, derived from RAD-16]

**Charge Posted** – The Department System Scheduler/Order Filler sends descriptions of potential procedure and material charges. [RAD-35]

**Account Management** - The ADT Patient Registration Actor informs the Charge Processor about creation, modification and ending of the patient’s account. [RAD-36]

**Displayable Report Storage** – A Report Creator sends a draft or final diagnostic Encapsulated Document report to the Report Repository. [EYECARE-7]

**Query Displayable Reports** – A Report Reader provides a set of criteria to select the list of entries representing diagnostic reports by patient, study, series, or instance known by the Report Repository. [EYECARE-8]

**Retrieve Displayable Reports** – A Report Reader requests and retrieves a diagnostic report from the Report Repository. [EYECARE-9]

The following table shows which transactions are used in which Integration Profiles.

**Table 2.4-1. Integration Profile Transactions**

Transaction \ Integration Profile	EYE CARE Workflow	Eye Care Charge Posting	Evidence Documents	Eye Care Displayable Report
Patient Registration [RAD-1]	X	X		
Placer Order Management [RAD-2]	X			
Filler Order Management [RAD-3]	X			
Procedure Scheduled [RAD-4]	X			
Query Modality Worklist [EYECARE-1]	X			
Modality Procedure Step In Progress [RAD-6]	X			
Modality Procedure Step Completed [EYECARE-6]	X	X		

<b>Transaction</b>	<b>Integration Profile</b>	<b>EYE CARE Workflow</b>	<b>Eye Care Charge Posting</b>	<b>Evidence Documents</b>	<b>Eye Care Displayable Report</b>
Modality Images/Evidence Stored [EYECARE-2]		X		X	
Storage Commitment [CARD-3]		X		X	
Patient Update [RAD-12]		X			
Procedure Update [RAD-13]		X			
Query Images [EYECARE-5]		X			
Retrieve Images [EYECARE-3]		X			
Charge Posted [RAD-35]			X		
Account Management [RAD-36]			X		
Query Evidence Documents [EYECARE-4]				X	
Retrieve Evidence Documents [RAD-45]				X	
Displayable Report Storage [EYECARE-7]					X
Query Displayable Report [EYECARE-8]					X
Retrieve Displayable Report [EYECARE-9]					X

## 2.5 Product Implementations

Developers have a number of options in implementing IHE actors and transactions in product implementations. The decisions cover four levels of optionality:

- For a system, select which actors it will incorporate. (Multiple actors per system are acceptable).
- For each actor, select which Integration Profiles it will participate in.
- For each actor-profile, select which optional transactions will be implemented. All required transactions must be implemented for the profile to be supported. (Refer to the Integration Profile Tables in sections 3-5)
- Finally, for each transaction, select which optional features will be supported. (Refer to the transaction descriptions in EYECARE-TF-2, or the appropriate domain TF)

Implementers should provide a statement describing which IHE Actors, IHE Integration Profiles, optional transactions and optional features are incorporated in a given product. The recommended form for such a statement is defined in Appendix C.

In general, a product implementation may incorporate any single actor or combination of actors. However, in the cases specified below, the implementation of one actor requires the implementation of one or more additional actors:

- The Image Archive shall be grouped with the Image Manager, and the Image Manager shall be grouped with the Image Archive.

- The Image Manager participating in Eye Care Integration Profile shall be grouped with a Performed Procedure Step Manager. The grouped Performed Procedure Step Manager shall be capable of being disabled via configuration.
- The Department System Scheduler/Order Filler participating in Eye Care Integration Profile shall be grouped with a Performed Procedure Step Manager. The grouped Performed Procedure Step Manager shall be capable of being disabled via configuration.

When multiple actors are grouped in a single product implementation, all transactions originating or terminating with each of the supported actors shall be supported (i.e., the IHE transactions shall be offered on an external product interface). The exceptions to this rule are any transactions defined between actors in the required groupings defined above.

For example, the Procedure Step In Progress/Completed transaction does not need to be supported between the Performed Procedure Step Manager and the Image Manager when these are grouped together in a single system.

When two or more actors are grouped together, internal communication between actors is assumed to be sufficient to allow the necessary information flow to support their functionality; for example, the Image Manager provides necessary information updates to the Image Archive to support its Query/Retrieve functionality. The exact mechanisms of such internal communication are outside the scope of the IHE Technical Framework.

### 3 EYE CARE Workflow (EYECARE)

The Eye Care Workflow Integration Profile establishes the continuity and integrity of basic patient and procedure data in the context of an eye clinic and/or an integrated hospital workflow scenario. This profile deals specifically with consistent handling of patient identifiers and demographic data. It also specifies the scheduling and coordination of procedure data to a wide variety of diagnostic imaging and testing equipment, and its reliable storage in an image management system from where it is available to support subsequent workflow steps, such as reporting. It also provides the ability for the acquisition devices to identify the actual procedure(s) that were performed. This enables further workflow steps such as automated billing.

This profile has much in common with the IHE Radiology Scheduled Workflow, but deals more explicitly with the eye care workflow and data requirements. See **RAD TF-1: 3.4** for the integrated workflow data model adopted by the IHE Technical Framework for HL7 messages and DICOM information objects. This data model offers three major levels of control for workflow:

- **Order:** A request for a Departmental Service
- **Requested Procedure:** Unit of work resulting in one or more reports, with associated codified, billable acts.
- **Scheduled and Performed Procedure Step:** the smallest unit of work in the workflow that is scheduled (work to do) or performed (work done).

A clear understanding of the workflow data model is essential to interpreting the *Eye Care Workflow Integration Profile*. Additional information may be found in Appendix A and B.

Although the major cases for eye care workflow are described in the following subsections, it is beneficial to also see the corresponding workflows in radiology. RAD TF-1: 3.3 has a description of the “normal” scheduled workflow when all three levels of control in the data model are fully utilized for known patients.

### 3.1 Actors/Transactions

Figure 3.1-1 diagrams the actors involved with this profile and the transactions between actors.

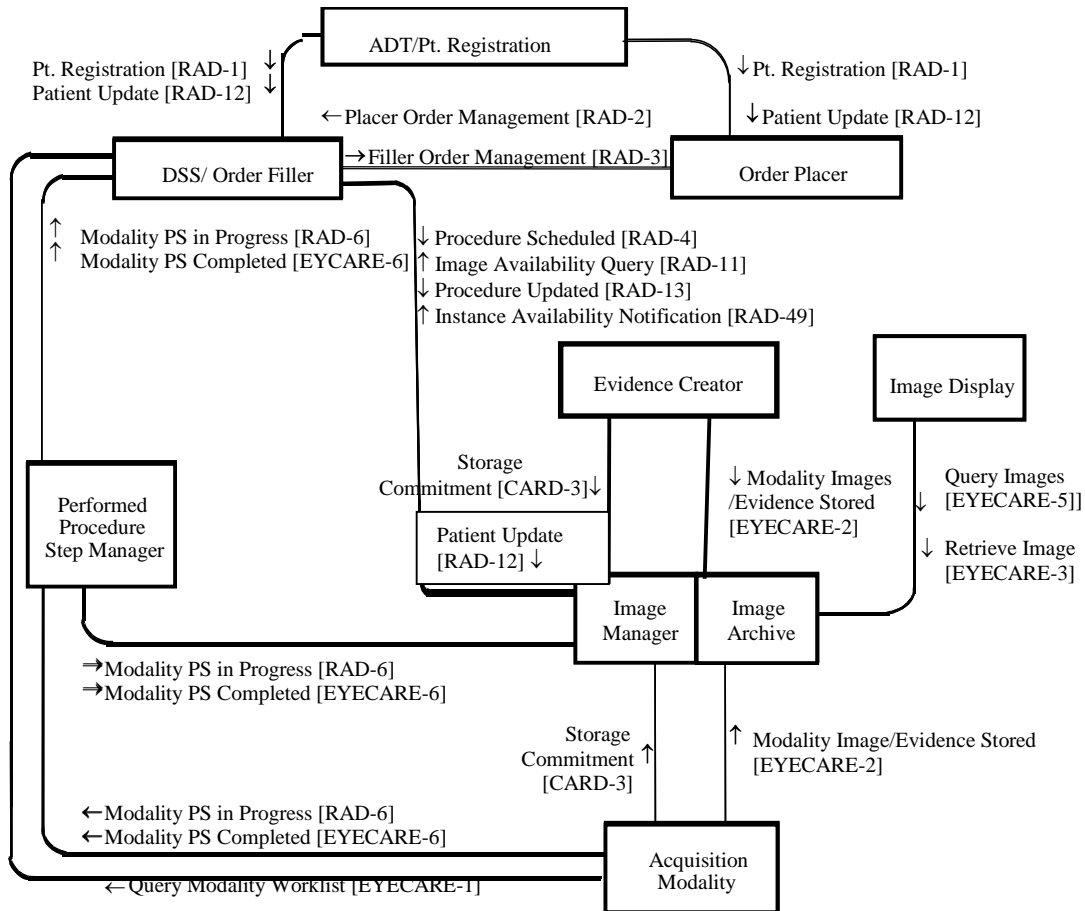

**Figure 3.1-1. Eye Care Workflow Diagram**

Note that this diagram maintains the actor and transaction names specified in the Radiology Technical Framework and Cardiology Technical Framework documents (RAD-TF and CARD-TF) for consistency of definitions.

Table 3.1-1 lists the transactions for each actor directly involved in the Eye Care Workflow Integration Profile. In order to claim support of this Integration Profile, an implementation must perform the required transactions (labeled “R”). Transactions labeled “O” are optional. A complete list of options defined by this Integration Profile that implementations may choose to support is listed in Section 3.2.

**Table 3.1-1. Eye Care Workflow - Actors and Transactions**

<b>Actors</b>	<b>Transactions</b>	<b>Optionality</b>	<b>Section</b>
ADT Patient Registration	Patient Registration [RAD-1]	R	RAD-TF 2: 4.1
	Patient Update [RAD-12]	R	RAD-TF 2: 4.12
Order Placer	Patient Registration [RAD-1]	R	RAD-TF 2: 4.1
	Patient Update [RAD-12]	R	RAD-TF 2: 4.12
	Placer Order Management [RAD-2]	R	RAD-TF 2: 4.2
	Filler Order Management [RAD-3]	R	RAD-TF 2: 4.3
Department System Scheduler/ Order Filler	Patient Registration [RAD-1]	R	RAD-TF 2: 4.1
	Patient Update [RAD-12]	R	RAD-TF 2: 4.12
	Placer Order Management [RAD-2]	R	RAD-TF 2: 4.2
	Filler Order Management [RAD-3]	R	RAD-TF 2: 4.3
	Procedure Scheduled [RAD-4]	R	RAD-TF 2: 4.4
	Query Modality Worklist [EYECARE-1]	R	EYECARE-TF 2: 4.1
	Modality Procedure Step In Progress [RAD-6]	R	RAD-TF 2: 4.6
	Modality Procedure Step Completed [EYECARE-6]	R	EYECARE-TF 2: 4.6
Acquisition Modality	Procedure Updated [RAD-13]	R	RAD-TF 2: 4.13
	Query Modality Worklist [EYECARE-1]	R	EYECARE-TF 2: 4.1
	Modality Procedure Step In Progress [RAD-6]	R	RAD-TF 2: 4.6
	Modality Procedure Step Completed [EYECARE-6]	R	EYECARE-TF 2: 4.6
	Modality Images/Evidence Stored [EYECARE-2]	R	EYECARE-TF 2: 4.2
Evidence Creator	Storage Commitment [CARD-3]	R	CARD-TF 2: 4.3
	Modality Images/Evidence Stored [EYECARE-2]	R	EYECARE-TF 2: 4.2
Image Manager/ Image Archive	Storage Commitment [CARD-3]	R	CARD-TF 2: 4.3
	Procedure Scheduled [RAD-4]	R	RAD-TF 2: 4.4
	Modality Procedure Step In Progress [RAD-6]	R	RAD-TF 2: 4.6
	Modality Procedure Step Completed [EYECARE-6]	R	EYECARE-TF 2: 4.6
	Modality Images/Evidence Stored [EYECARE-2]	R	EYECARE-TF 2: 4.2
	Storage Commitment [CARD-3]	R	CARD-TF-TF 2: 4.3
	Patient Update [RAD-12]	R	RAD-TF 2: 4.12
	Images Availability Query [RAD-11]	R	RAD-TF 2: 4.11
	Procedure Updated [RAD-13]	R	RAD-TF 2: 4.13
Query Images [EYECARE-5]	R	EYECARE-TF 2: 4.5	

Actors	Transactions	Optionality	Section
	Retrieve Images [EYECARE-3]	R	EYECARE-TF 2: 4.3
Performed Procedure Step Manager	Modality Procedure Step In Progress [RAD-6]	R	RAD-TF 2: 4.6
	Modality Procedure Step Completed [EYECARE-6]	R	RAD-TF 2: 4.7
Image Display	Query Images [EYECARE-5]	R	EYECARE-TF 2: 4.5
	Retrieve Images [EYECARE-3]	R	EYECARE-TF 2: 4.3

Refer to Table 2-1 for other profiles that may be pre-requisites for this profile.

### 3.2 Eye Care Workflow Integration Profile Options

Many Actors have Options defined in order to accommodate variations in use across domains or implementations. Options that may be selected for this Integration Profile are listed in the table 3.2-1 along with the Actors to which they apply. Certain of these Options are required for implementation by actors in this Profile (although they may be truly optional in other Profiles).

**Table 3.2-1: Eye Care Workflow - Actors and Options**

Actor	Option Name	Optionality	Vol & Section
ADT Patient Registration	<i>No options defined</i>	-	-
Order Placer	Appointment Notification [RAD-48]	O	RAD-TF 3: 4.48
Department System Scheduler/Order Filler	Billing and Material Management (see Note 1)	O	RAD-TF 2: 4.7
	Assisted Acquisition Protocol Setting	O	RAD-TF 2: 4.6
	PPS Exception Management	O	RAD-TF 2: 4.7
	Appointment Notification [RAD-48]	O	RAD-TF 3: 4.48
	Instance Availability Notification [RAD-49]	O	RAD-TF 3: 4.49
	Images Availability Query [RAD-11]	O	RAD-TF 2: 4.11

Actor	Option Name	Optionality	Vol & Section
Acquisition Modality	Patient Based Worklist Query (see Note 2)	R	EYECARE-TF 2: 4.1
	Broad Worklist Query (see Note 2)	R	EYECARE-TF 2: 4.1
	Billing and Material Management (see Note 1)	O	RAD-TF 2: 4.7
	Assisted Acquisition Protocol Setting	O	RAD-TF 2: 4.6
	PPS Exception Management	O	RAD-TF 2: 4.7
	Eye Care Image Option	C See Section 3.2.1	EYECARE-TF 2: 4.2
	Encapsulated PDF Option for Evidence Documents	C See Section 3.2.1	EYECARE-TF 2: 4.2
	Eye Care Measurement Option	C See Section 3.2.1	EYECARE-TF 2: 4.2
	Relative Image Position Coding Option	O	EYECARE-TF 2:4.2
	Stereo Relationship Option	O	EYECARE-TF 2:4.2
Evidence Creator	<i>No options defined</i>	-	-
Image Manager/ Image Archive	PPS Exception Management	O	RAD-TF 2: 4.7
	Instance Availability Notification [RAD-49]	O	RAD-TF 3: 4.49
	Stereo Relationship Option	O	EYECARE-TF 2:4.2
Image Display	Relative Image Position Coding Option	O	EYECARE-TF 2:4.3
	Encapsulated PDF Option for Evidence Documents	O	EYECARE-TF 2: 4.2
	Stereo Relationship Option	O	EYECARE-TF 2:4.3
Performed Procedure Step Manager	<i>No options defined</i>	-	-

Note –1: The options in the table are defined in the transitions referenced in the Vol & Section column. For example, the Billing and Material Management option is referenced to section RAD-TF2: 4:7. If you look at table 3.3-1 you can see that this option belongs to transaction Modality Procedure Step Completed.

Note-2: The Radiology TF requires that the Acquisition Modality support at least one of the Worklist Query choices (i.e. Patient and Broad). Eye Care requires support for both options.

The Acquisition Modality and Image Manager/ Image Archive will likely support a variety of DICOM SOP Classes. It is expected that this level of optionality will be documented by a reference in the IHE Integration Statement (see appendix C).

### **3.2.1 Acquisition Modalities Storage Options**

The DICOM Standard defines certain Image Storage SOP Classes that are applicable to EYECARE Acquisition Modalities, such as Ophthalmic 8 bit Photography Image Storage, Ophthalmic Tomography Image Storage, etc., see EYECARE TF: 2, 4.2.5 for the complete list of SOP Classes. Acquisition Modalities for whom a DICOM Image SOP Class is defined are required to support the Eye Care Image Option in order to comply with the Eye Care Workflow Profile.

Certain Acquisition Modalities are yet to be defined in DICOM. For these Acquisition Modalities, the support of the Encapsulated PDF Option for Evidence Documents does comply with the Eye Care Workflow Profile. However, once they are defined by DICOM, then it is required by the Eye Care Workflow Profile that the Acquisition Modalities support the Eye Care Image Option with the appropriate DICOM SOP Class. The Encapsulated PDF Option may be supported as an addition to the appropriate DICOM SOP Class.

Note: For example, in IHE Year 1 there was not a DICOM SOP class defined for Ophthalmic Tomography, therefore, these types of Acquisition Modalities only had the capability to support the Encapsulated PDF Option for Evidence Documents. But in IHE Year 2 DICOM has defined such a SOP Class, therefore, they are required to support the approved DICOM SOP Class and additionally they may also support the Encapsulated PDF Option. Support for only the Encapsulated PDF option is no longer compliant with the Eye Care Workflow Profile.

Note: The DICOM standard does not define use of a specific version of PDF when encapsulated PDF is used. This may result in incorrect display of reports when using a different PDF version of software from that which was used to create the files. Other issues arise when using only PDF with pixel data as the files are large and have difficulties with display. IHE EYECARE defines specific versions required for support see EYECARE TF2: 4.2.

The DICOM Standard defines certain Measurement Storage SOP Classes that are applicable to EYECARE Acquisition Modalities, such as Lensometry Measurement Storage, Subjective Refraction Measurement Storage, etc., see EYECARE TF: 2, 4.2.8 for the complete list of SOP Classes.

Acquisition Modalities for whom a DICOM Measurement SOP Class is defined are required to support the Eye Care Measurement Option in order to comply with the Eye Care Workflow Profile.

### **3.2.2 Ophthalmic Photography Relative Image Position Coding Option**

When a healthcare provider is reading fundus photos it is occasionally difficult to determine what location in the retina, or even which eye, he or she is viewing. Laterality (right vs left eye) is a required attribute in DICOM Ophthalmic Photography Image SOP Classes, enabling image display vendors to display this information. However, the DICOM attribute Relative Image Position Code Sequence is an optional attribute and often not conveyed in the OP images. The Relative Image Position Coding option requires this information to be conveyed by Acquisition Modality Actors.

When Acquisition Modality Actors support this option it enables Image Display Actors to display field position clearly to the user.

Healthcare providers reading fundus images often are most comfortable viewing them in a particular order. The characteristics of this choice are user specific and may vary among healthcare providers. Implementation of the Relative Image Position Coding option also enables Image Display Actors to provide this functionality.

As an example of implicit display of relative image position, the Image Display Actor may display exactly those images in an OP series that have been tagged with relative image position codes corresponding to a particular protocol such as the Joslin 3-field protocol. Their absolute location of those images in the display layout should then be a function of their relative image position codes. In this example, the application may choose to display or not to display other images in the series (effectively “rejects” relative to the protocol); however, if such rejects are displayed, their position in the display layout should unambiguously indicate their lack of relative image position codes.

The Image Display actor may have alternate display modes that do not show the relative image position; for example, the Image Display actor may allow the user to toggle the direct display of relative image position code meanings on or off, or it may allow toggling between display of all images in a series or a display layout conforming to a particular protocol.

The Relative Image Position option for an Image Display actor does not specify a mechanism for hanging protocols for OP images, although hanging protocols supporting relative image position codes may be used to satisfy the requirements. Other attributes such as laterality, acquisition date and time, etc. should also be considered for hanging protocols.

The eye care domain may utilize many different image position codes (such as Diabetic Retinopathy Study fields, Joslin fields, etc). DICOM CID 4207 is the location where this list is managed. Since healthcare providers may wish to utilize image position codes beyond what is defined in DICOM CID 4207 according to other acquisition protocols, this option also requires that Acquisition Modality Actors be able to configure additional codes (beyond what is defined by DICOM CID 4207) based upon IHE extensions and the requirements of the user.

Note: IHE will work with DICOM to include IHE defined code extensions.

It should be understood that relative image position codes are not intended to communicate laterality or stereometric relationship information, there being other DICOM attributes and objects for these other purposes.

### **3.2.3 Radiological Studies of the Eye**

Eye care healthcare providers frequently order radiological studies of the eye and surrounding anatomy. In many instances the interpretation of the study by a radiologist is all that is required. However, in certain instances such as suspected disease or trauma of the orbit (eye socket) or sinuses the ophthalmologist considers both a radiologist report and personal evaluation of the imaging study. One common example would be an orbital CT scan looking for fracture of the

orbital floor, which may require surgical repair. Another example is the use of an orbital MRI looking for suspected tumor. Plain x-ray films of the facial bones may be obtained when there is trauma near the eye. In all these instances the ophthalmologist gains specific diagnostic value by his or her own evaluation of the images and may also use this function in the OR to guide surgical intervention.

Image Display and Archive Actors are recommended to support the radiological SOP Classes defined in EYECARE TF: 2, 4.2.5.

### 3.2.4 Stereo Relationship Option

Stereo photography such as for the optic disk requires determination of the stereo relationships between two OP images. The DICOM standard provides a mechanism for storing separate stereo relationship objects referencing the left and right images. Typical real world examples of usage include:

**Glaucoma** - A patient with a family history of glaucoma presents for a routine eye examination and was found to have elevated intraocular pressure and optic cup enlargement and asymmetry. The ophthalmologist ordered a glaucoma work-up including stereoscopic photographs of the optic nerve head bilaterally. The ophthalmic photographer obtains non-simultaneous stereo pair photographs of the optic nerve head in both eyes. The images are used for serial follow-up of the discs using a handheld stereoscopic viewing device.

**Diabetic macular edema** - A patient with a 15-year history of type II diabetes presents for teleretinal screening of diabetic retinopathy. A standard 7 field ETDRS series is obtained with non-simultaneous stereoscopic pairs obtained for each of the standard fields captured. The patient had difficulty remaining still, and the photographer was fairly certain that some of the peripheral photos had vertical disparity in the stereo pairs. The images are used for evaluation of the macula using a CRT and polarizing stereoscopic goggles.

**Macular hole** - A patient with a history of old trauma in the right eye presented for evaluation of chronically decreased vision. Clinical examination was consistent with a full thickness macular hole, and stereoscopic photographs of the macula were ordered. A 30 degree color photograph centered on the fovea was obtained with a camera that used fixed angle “simultaneous” capture of a stereoscopic pair for photo documentation of the condition.

## 3.3 Eye Care Workflow Process Flow

The Eye Care administrative process flow is shown in Figure 3.3-1. For comparison with radiology, see RAD-TF 1:3.3. To facilitate such comparison for those readers familiar with RAD-TF, the differences between the radiology Process Flow Diagrams and those in eye care are shown in green in the figures. The functionality of those data flows is specified within the specific transactions invoked by the EYECARE-TF.

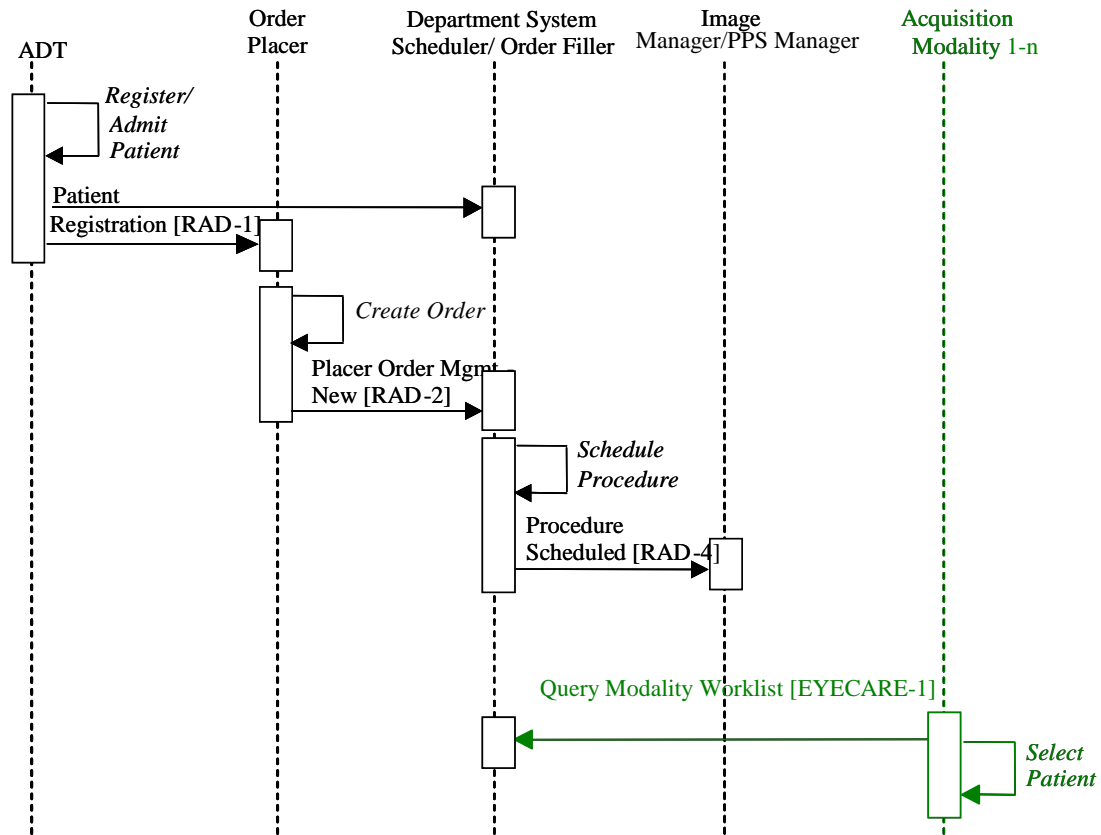
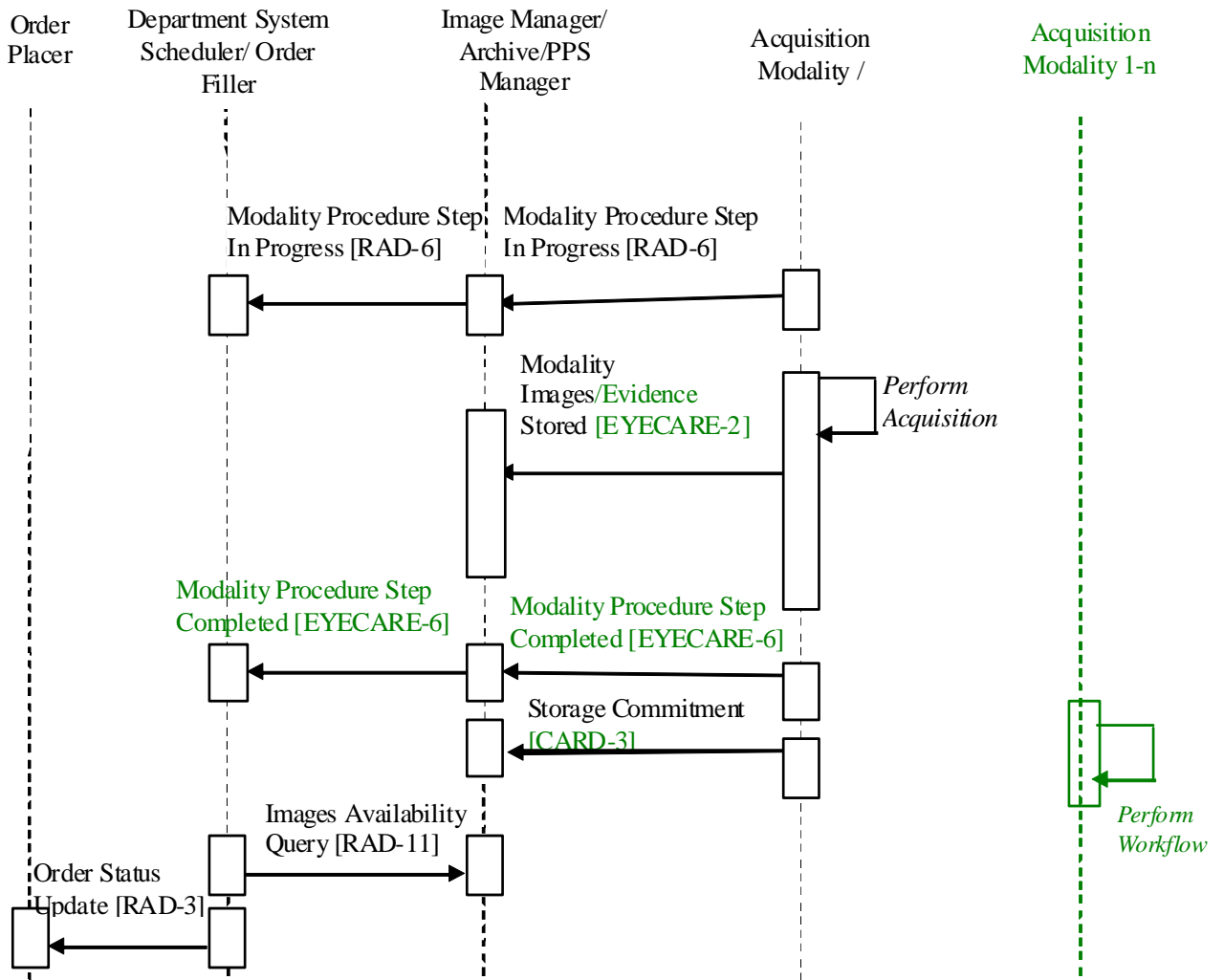

**Figure 3.3-1. Workflow: Administrative Process Flow**

The following should be noted in relation to the Administrative process flow:

- *Patient Registration*: The Patient Registration data is broadcast to several systems, including the Order Placer and the Department System Scheduler/Order Filler (DSS/OF).
- *Create Order*: The Order Placer is the repository for all patient orders.
- *Schedule Procedure*: The DSS/OF associates the order with one or more Requested Procedures that have to be performed to satisfy the order. Each Requested Procedure prescribes a number of actions that have to be performed by Acquisition Modalities. Actions are specified in Scheduled Procedure Steps (SPS) based on timing and sequencing, and on modality. Scheduled Procedure Steps are scheduled, i.e., assigned a time slot and performing resource (modality), and are made available for Modality Worklist Query.
- *Query Modality Worklist*: The Modality Worklist (MWL) query may be broad (get a list of scheduled procedures from which one will be selected), or patient-specific (provided with sufficient query keys to get back the scheduled procedure for a single patient). Eye Care procedures may be performed on multiple Acquisition Modalities, therefore, multiple devices may perform the queries.
- *Select Patient*: In the event of a single SPS in the MWL response, a modality may optimize the Select Patient function to select that SPS without further explicit user action.

See Appendix A and B for further description.



**Figure 3.3-2. Workflow: Procedure Performance Process Flow**

The following should be noted in relation to the Procedure Performance process flow:

- *Modality Procedure Step In Progress*: This allows the Acquisition Modalities to specify that they have started the procedure and which is linked to the information provided in the Query Modality Worklist transaction.
- *Perform Acquisition*: Each Modality may produce a variety of images and other evidence (visual fields, refractive and biometry information, etc.) that are stored to the Image Manager/Archive. The Image Manager/Archive must support all the object types as specified

by the Eye Care Option, the Eye Care Measurement Option and the Encapsulated PDF Option (see EYECARE-TF-2: 4.2).

NOTE: DICOM is in the process of defining Structured Reports for evidence documents such as visual fields and biometry information. Until this time, this information may be generated using DICOM Encapsulated Postscript.

- *Modality Procedure Step Complete and End Procedure*: Modality Procedure Step Complete also includes Modality Procedure Step Discontinued. The simple transmission of a Complete or Discontinued does not indicate that a modality is then available, due to multi-step procedures (diagnostic images, evidence documents) and multi-modality cross-dependencies. It is a function of the DSS/OF (outside the scope of this document) to determine when to end the procedure, and declare the modality resources are available for another procedure. As part of this transaction, EYECARE-6 (an extension to RAD-7) requires the modality accurately convey the Performed Protocol Code Sequence. This requirement enables the ability to create automatic billing claims for products implementing the *Charge Posting Integration Profile*.
- *Storage Commitment*: The Image Manager/Archive accepts responsibility for stored images and evidence, allowing the modality to delete the data from its local storage. The Image Manager/Archive shall support devices that may be intermittently connected to the network and temporarily unable to receive Storage Commitment messages.
- *Filler Order Management - Status Update*: Status Update transactions may be sent to the Order Placer at several points in the workflow, although only the update after the last Modality Procedure Step Complete are shown.

### 3.3.1 Extension to Query Modality Worklist for Eye Care [EYECARE-1]

The ADT/Patient Registration actor transmits information regarding the assigning authority (issuer) of the Patient ID to the DSS/OF Actor, which is defined in [RAD-1], see RAD-TF 2: 4.1. However, [RAD-5] (see RAD-TF 2: 4.5), does not required the DICOM attribute “Issuer of Patient ID” be filled in by the DSS/OF actor if asked by the Acquisition Modality during a Modality Worklist query. This extension requires support for this attribute, see EYECARE-TF 2: 4.1 for complete specifications.

A key feature in Eye Care is that patient identity is a critical issue for the Acquisition Modality itself, because of longitudinal data requirements. For example, visual field analyzers persistently store longitudinal data in order to perform glaucoma progression analysis. Ensuring that all the data comes from one patient, and that all data from that patient is used to calculate the progression, is essential.

Traditionally, many instruments have used the patient name and date of birth to determine the identity of patient records, because patient ID’s were not available from an electronic health record and were unreliable. As electronic health record systems become available to manage patient ID’s systematically, these are typically used as the unique key for the identity of the patient record. However, this is within the context of their own “namespace” of ID’s. In order for an acquisition modality to confidently determine the identity of its patient records based on the Patient ID, it also must know this context. This can be provided by the “Issuer of Patient ID” attribute.

Note: When an Issuer of ID is provided to the acquisition modality, it should determine patient identity based on the (Issuer of Patient ID, Patient ID) combination, rather than patient name and date of birth. The acquisition modality should still provide patient reconciliation logic for legacy records.

### 3.4 Eye Care Workflow Use Cases

This section describes the specific use cases and process flows defined for the Eye Care Workflow Profile.

**Clinical Context:** EYECARE addresses three workflow scenarios, standalone eye care clinics, large eye care groups and hospital-based eye care departments. We understand that others scenarios exist, i.e. Eye Care Referrals, Tele-medicine, etc. However, they are not being formally addressed and will be considered in future versions.

Note: Even though not all clinical scenarios are being formally addressed, the defined workflow cases may actually apply to these scenarios. However, this has not been determined.

We are addressing scenarios expecting the patients to be registered and the procedures to be ordered. There are clinical scenarios where orders may not be placed. They will be addressed in future versions.

The following two examples show two typical scheduled workflows that may occur. They are very similar in the IHE transactions performed; however, the difference is whether a manual or automatic order was created for a procedure.

Note: For the purposes of this Technical Framework, the term "order" shall be construed in the most generic sense. The extent to which an order is treated as a healthcare provider's order shall be a function of legal jurisdiction. When the procedure involved is deemed not to require a healthcare provider's order, the "order" may be viewed simply as a requirement to preserve data integrity in the workflow.

#### 3.4.1 Workflow Example with Manual Procedure Order

The patient has been registered in an ADT/Patient Registration actor, a healthcare provider has written a procedure order manually, and a procedure step has been scheduled. The technician uses the Acquisition Modality to query for a worklist. This may be either a patient query (using parameters to identify the patient uniquely), or a broad query (for all procedure steps scheduled for the modality). The modalities use the DICOM modality worklist service to query the DSS/OF, which responds with a worklist. This is displayed on the modality. The modality may then use the DICOM query / retrieve service to retrieve longitudinal data to display to the technician prior to the acquisition, or to display to the healthcare provider after the acquisition (for implicit post-processing involving longitudinal data). The technician selects the appropriate worklist item. The technician performs the acquisition based upon the scheduled protocol code identified in the worklist, or the technician may determine that the requested protocol code was insufficiently specific, and select a different code for acquiring the information. For example, a visual field may have been ordered and the code to convey the procedure and protocol is Visual Field. This code is not specific enough to choose the algorithm needed. The modality uses the DICOM performed modality procedure step service to send a complete message to either the ordering system or storage server, depending on the configuration. This message contains a lot of key

information such as the performed procedure step's protocol code (i.e. what protocol was actually performed on the patient) that later may be used for charge processing (the protocol code is mapped to a billing code). The modality uses the DICOM storage commitment service to request that the storage server take responsibility for persistent storage of the previously stored acquisition data. The storage server responds asynchronously to acknowledge the storage commitment; this may be almost immediate, or it may be after the storage server has transferred the acquisition data to secondary media. After receiving a positive storage commitment response, the modality may clear the acquisition data from its disk.

In summary, this example allows for specific detailed procedures and protocols to be requested in the order. It supports the scenario that a different protocol could be performed. If what was performed is not what was ordered, the order is corrected on the instrument and sent back to the department ordering system. This enables the ability to charge for the "actual" performed protocol automatically (if the Charge Posting Integration Profile is supported).

### **3.4.2 Workflow Where the Procedure Ordered is an Automatic Eye Care Order**

There are often a number of procedures performed on patients when they arrive in the clinic, without need for healthcare provider orders. For example, an eye care order may be created automatically when a patient is scheduled for an eye exam, placing the patient's name and order information on the modality worklist of several different instruments in the eye care clinic. Examples may include a lensometer and an autorefractor, etc. In this scenario, not all of the orders are performed. For example, if the patient does not have glasses, no lensometry measurement is required.

The patient has been registered in an ADT/Patient Registration actor, and a number of automatic orders are generated by the Order Placer or DSS/OF (i.e. an automatic eye care order is placed). The technician uses the Acquisition Modality actor to query the DSS/OF for a worklist. This may be either a patient query (using parameters to uniquely identify the patient), or a broad query (for all procedure steps scheduled for the modality). This is displayed on the modality. At this time, the technician recognizes the automatic eye care order and therefore determines that he/she needs to select the appropriate protocol code and perform the acquisition. The modality uses the DICOM performed procedure step service to send a start message to either the order system or storage server depending on the configuration. The technician performs an acquisition for the patient. When the technician selects to save the acquisition, the modality uses the DICOM storage service to store the acquisition data to the storage server. Additional acquisitions may occur as part of the performed procedure step, each resulting in a DICOM storage command. The technician selects a UI mechanism on the modality to indicate the end of the procedure step. The instrument uses the DICOM performed modality procedure step service to send a complete message to either the ordering system or storage server, depending on the configuration. This message contains a lot of key information such as the performed procedure step's protocol code (i.e. what protocol was actually performed on the patient) that later may be used for charge processing (the protocol code is mapped to a billing code by the ordering system). The modality uses the DICOM storage commitment service to request that the storage server take responsibility

for persistent storage of the previously stored acquisition data. The storage server responds asynchronously to acknowledge the storage commitment; this may be almost immediate, or it may be after the storage server has transferred the acquisition data to secondary media. After receiving a positive storage commitment response, the modality may clear the acquisition data from its disk.

Not all of the automatically generated orders will be performed. The DSS/OF is responsible to remove all unused worklist items that have not been performed on this patient. The triggering mechanism for removing these automatic orders from the device specific Acquisition Modality Worklist will be defined by the DSS/OF and configured for the specific needs of the clinic. This is outside the scope of IHE.

The above workflow may occur on many different modalities for which automatic orders were created in the clinic.

This scenario is more completely documented in Appendix A.3 Workflow Examples using Automatic Orders.

### 3.5 Workflow Concepts in Practice

The IHE “Real World” model for Scheduled Workflow described above offers three major levels of control that can be used to customize a broad range of specific workflow situations:

- **Order:** A request for an Imaging Service
- **Requested Procedure:** Unit of work resulting in one report with associated codified, billable acts.
- **Scheduled and Performed Procedure Step:** the smallest unit of work in the workflow that is scheduled (work to do) and/or performed (work done).

The DSS/OF uses the Universal Service ID in each order that it receives to determine what specific Requested Procedures are needed, and for each Requested Procedure, what Procedure Steps need to be scheduled.

A departmental Procedure Plan may be used in the DSS/OF Actor to predefine Orders that may be requested from the eye care department. Generally these orders are defined in the Order Placer. Definitions will specify both the procedure code and the Scheduled Procedure Steps for each Requested Procedure.

The figure below defines an example of the breakdown of a “rule out glaucoma” Order.

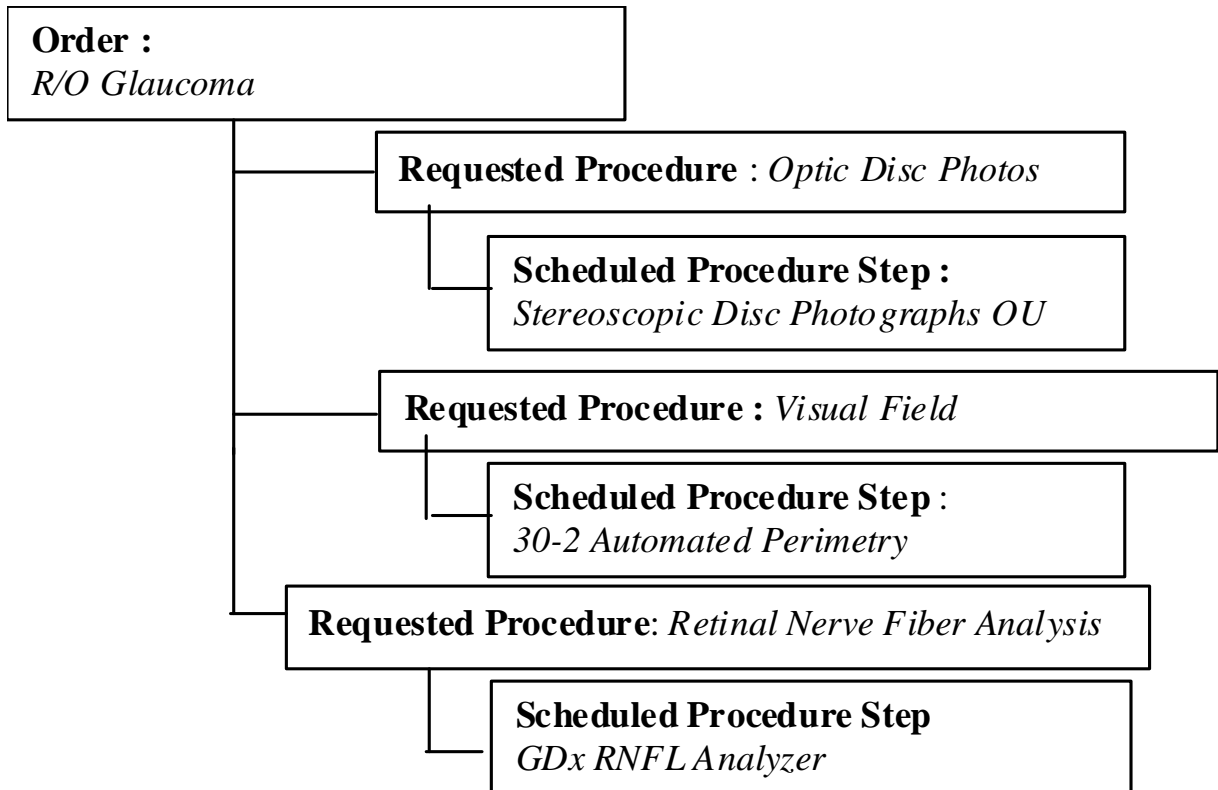

In this Procedure Plan, for this specific Order, three Requested Procedures are defined. Each Requested Procedure has been scheduled as a separate Scheduled Procedure Step, because the patient may have each one performed at a different time. In addition, more than one ophthalmologist may be involved in the interpretation of the Requested Procedures. This is the way this institution has decided to handle this Order. Another Institution may choose to require the same ophthalmologist to read some or all of the procedures. In that case, its Procedure Plan would define same Order to have a single Requested Procedure with two or three Scheduled Procedure Steps.

Many Orders processed in an Eye Care Department would have a simpler breakdown such as this Optic Disc Photos example.

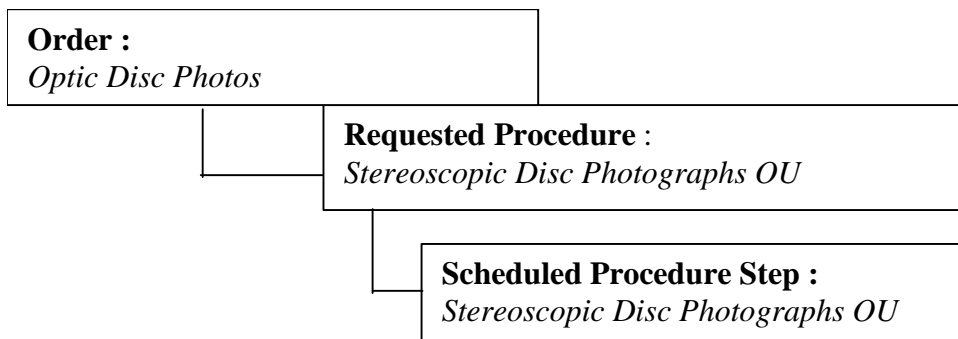

It should be noted that the three level Order breakdown has been defined in the IHE Scheduled Workflow so that any type of Order, from the simple case to the more complex case may be handled by the same workflow concepts, thus providing a general approach that can be easily customized by each department in the definition of its Procedure Plan.

In the IHE Scheduled Workflow, the **Accession Number identifies the Order**. The **Requested Procedure ID** distinguishes among Requested Procedures when an Order requires multiple Procedures. IHE sets a common meaning for these two terms to provide healthcare providers with a consistent and non-ambiguous access across different vendor products (RIS, PACS and Modalities).

### 3.6 Workflow Use Cases

Each process flow is introduced with an overview of the end-user issue addressed (“Clinical Context”) and the approach taken in the Technical Framework (“IHE Context”).

**Clinical context:** This reflects the situation where a patient is admitted to the facility (i.e. a clinic or hospital), and an eye care procedure is ordered and scheduled, similar to a radiology procedure (i.e. the patient has been registered and an order has been placed for that patient before any diagnostic testing is performed).

**IHE Context:** This section describes the “normal” scheduled workflow when all three levels of control (order, requested procedure, and scheduled/performed procedure steps) in the IHE data model are fully utilized to request a procedure for known patients. This process flow provides the basis for understanding the specific use cases described in section 3.6.

**IHE Context:** There are 7 specific use cases being addressed, E1 through E7. They are similar as the patients are registered at the ADT/Patient Registration actor with the variation being where the order is placed (either the Order Placer or DSS/OF).

Many of the use cases include the set of transactions necessary for post-hoc updating of patient information. In the Radiology Technical Framework, this is specified in a separate Patient Information Reconciliation Profile, but it was decided to include it in the eye care workflow so that all vendors would support it.

The use cases parallel those defined in the Radiology Patient Information Reconciliation Profile (RAD-TF 1:4.4). To facilitate comparison for those readers familiar with RAD-TF, the differences between the radiology Process Flow Diagrams and those in eye care are shown in green in the figures in the following subsections.

There are six specific Use Cases defined for EYECARE Workflow, E1 through E6, whose variations occur, based on whether or not and where a patient is registered, as well as whether or not and where an order is placed. These variations are listed in Table 3.6-1. EYECARE use cases E1 through E6 correspond closely to RAD-TF Patient Information Reconciliation use cases 1 through 6.

Additional use case, E7: Cancel Procedure is not shown in the Table and follows use Case C8 in the CARD-TF 1 document.

**Table 3.6-1. EYE CARE Workflow Cases**

<b>Order Placement</b>	<b>Order Placed at Order Placer</b>	<b>Order Placed at Department System Scheduler/Order Filler</b>	<b>Order Not Placed</b>
<b>Patient Registration</b>			
<b>Patient Registered at ADT</b>	<b>Case E1</b>	<b>Case E2</b>	<b>Case E3</b>
<b>Patient Registered in the Department (see note)</b>	Not Applicable - the Order Placer requires the patient registration from the ADT system	<b>Case E4</b>	<b>Case E5</b>
<b>Patient Updated</b>	<b>Case E6</b>	<b>Case E6</b>	<b>Case E6</b>

Note: Patient is registered in the department either in the DSS/OF system, or manually (temporary ID assigned on paper and manually entered into the modality).

Note: The transactions for Modality Image/Evidence Stored and Storage Commitment are not shown in the following subsections, and selected Order Status Update transactions are not shown, as they do not impact the process control workflow. Also only selected transactions for “Modality N” are shown to indicate the multi-modality nature of the Process Flow.

Also note that the Performed Procedure Step Manager as shown on the Process Flow diagrams is presumed to be grouped with the Image Manager for the purpose of presentation. In actual implementations it may be grouped with the Department System Scheduler/Order Filler with corresponding changes in the flow of PPS related transactions between the Image Manager and Department System Scheduler/Order Filler.

### **3.6.1 Case E1: Patient Registered at ADT and Procedure Ordered at the Order Placer**

**Clinical Context:** This corresponds to the more traditional Radiology Structured Workflow, where an order is placed in the hospital ordering system or practice management system for the diagnostic testing. Since the order is placed before the procedure begins, common identifiers can be used to enable the coordinated presentation and electronic distribution of all of the information related to the eye care procedure.

**IHE Context:** This case includes the full scheduled workflow when all three levels of control (order, requested procedure, and scheduled/performed procedure steps) in the IHE data model are fully utilized to request a procedure (see section 3.3).

The patient may be registered at the ADT system as a known patient with complete demographics. Orders are created at the Order Placer, and whose procedures are scheduled at the

Department System Scheduler/Order Filler (DSS/OF).

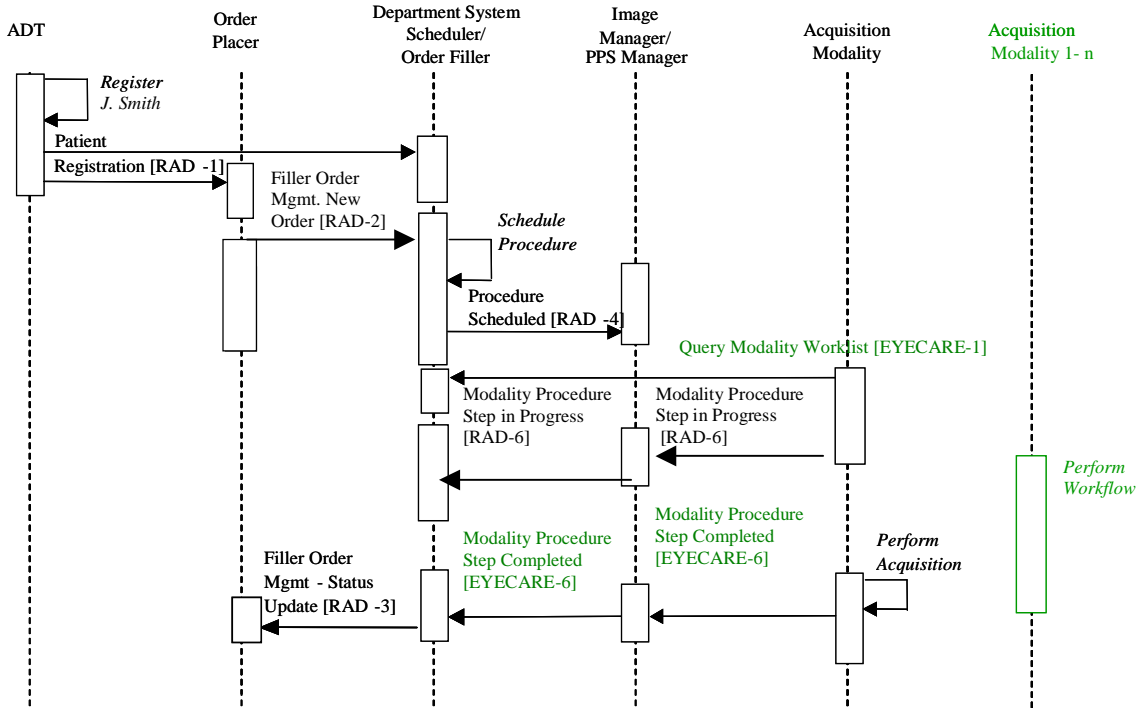

**Figure 3.6-1. Patient Registered at ADT and Ordered at the Order Placer – Case E1**

Significant Transactions (see also Section 3.3):

- In order to provide billing information for the DSS/OF, the Acquisition Modality is required to support the ability to convey the Performed Protocol Code Sequence as defined in EYECARE-6

**3.6.2 Case E2: Patient Registered at ADT and Procedure Ordered at DSS/OF**

**Clinical Context:** This scenario is closely akin to Case E1, however, an order is not placed in the traditional practice management system or hospital ordering system, but rather, the procedure information is entered at the Departmental System, which then submits the information to the practice management system or hospital ordering system. This workflow is typical of many clinics and institutions, and alleviates the need to have an Order Placer system terminal in the eye care department.

**IHE Context:** This case is based on case E1. However, in this situation the order for a procedure for a registered patient is generated by the Department System Scheduler/Order Filler and submitted to the Order Placer. Procedures are scheduled normally and acquisition systems use Modality Worklist.

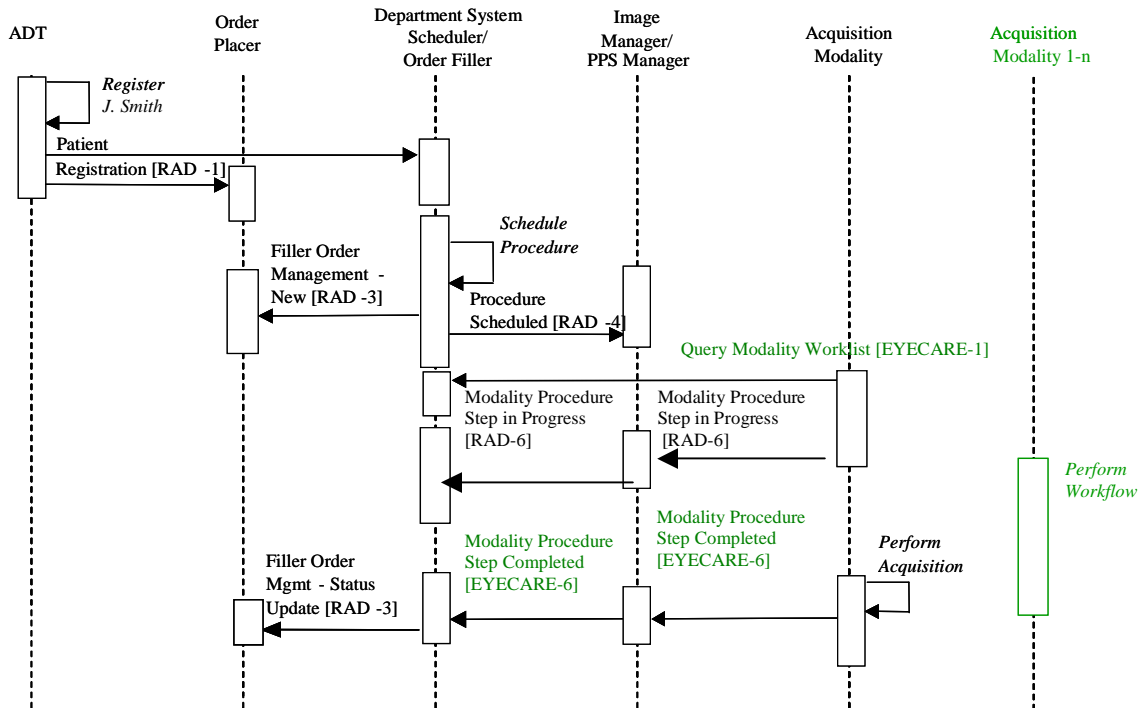

**Figure 3.6-2. Patient Registered at ADT and Ordered at DSS/OF – Case E2**

Significant Transactions:

- A Filler Order Management (New Order) transaction [RAD-3] is sent from Department System Scheduler/Order Filler to the Order Placer.

### 3.6.3 Case E3: Unidentified Patient Registered at ADT but Completed at Modality Prior to Order

As in cases 1 and 2, this uses a permanent Patient ID generated by the ADT. However, no order entry or scheduling takes place before the Acquisition Modality performs the procedure. A permanent Patient ID and a temporary name are manually entered at the Acquisition Modality (typically, from a card) and conveyed to the Department System Scheduler/Order Filler and the Image Manager by the Acquisition Modality. Subsequently, the Department System Scheduler/Order Filler generates and submits an order to the Order Placer. When the patient information is reconciled, the ADT sends the Patient Update messages to both the Order Placer and the Department System Scheduler/Order Filler. The Department System Scheduler/Order Filler sends a Patient Update message to the Image Manager.

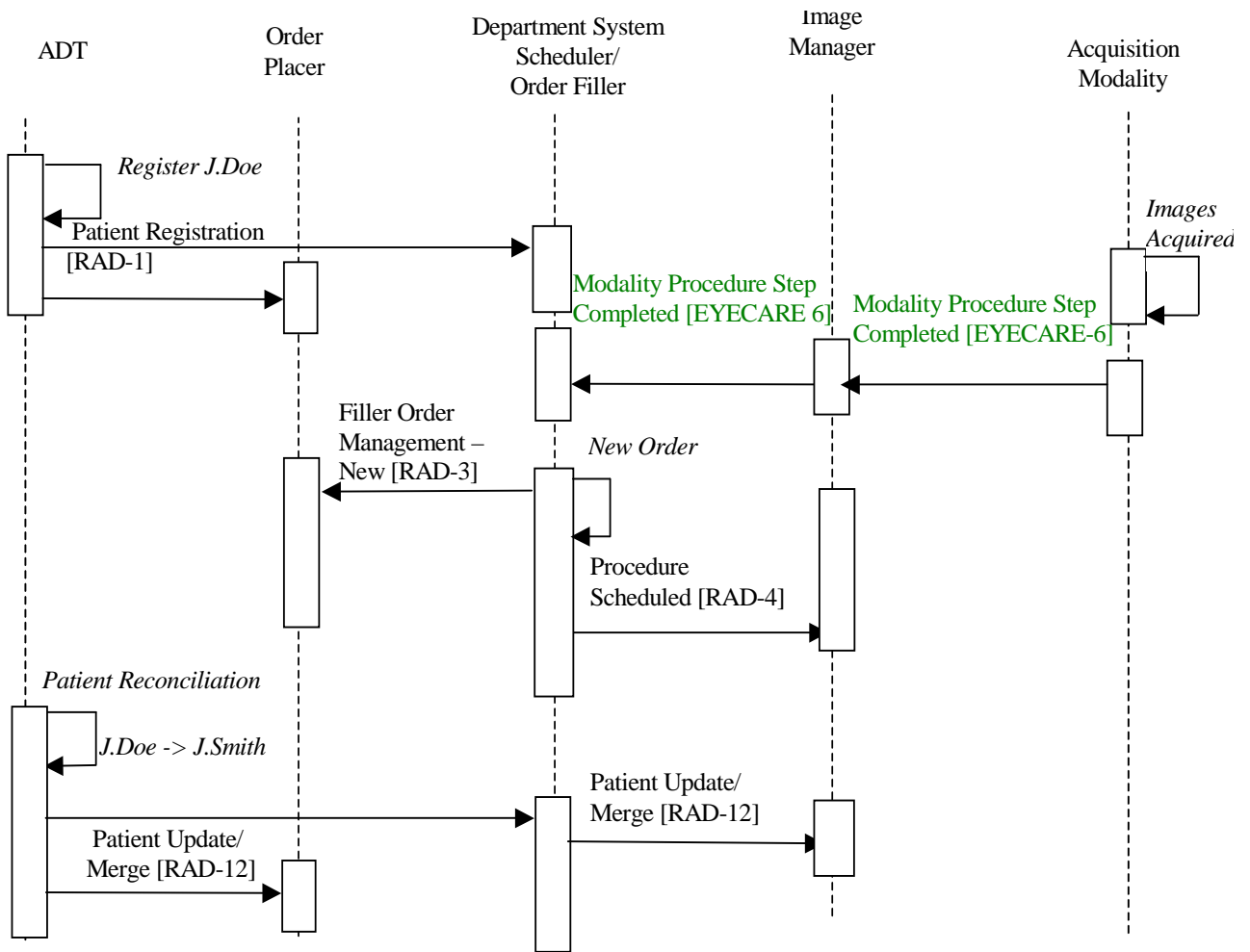

**Figure 3.6.5-1 Unidentified Patient – Case E3**

**Significant Transactions:**

- On receiving a Modality Procedure Step Completed [EYECARE-6], the Department System Scheduler/Order Filler recognizes it as an unscheduled case.
- The Department System Scheduler/Order Filler sends a Filler Order Management (New Order) transaction [RAD-3] to the Order Placer.
- Using the information from the Procedure Step Completed transaction and the placed order, the DSS/OF creates a new Requested Procedure record and sends a Procedure Scheduled transaction to the Image Manager.

Note: The Procedure Scheduled Transaction requires that the DSS/OF uses the same Study Instance UID as sent the MPPS message, created by the modality.

- To reconcile the patient information, the ADT may register a new patient and merge the temporary patient with the correct patient and send both registration and merge transactions.
- If a permanent Patient ID was assigned, then the ADT may only send a Patient Update transaction with proper information.
- The DSS/OF sends a Patient Update transaction to the Image Manager.

#### **3.6.4 Case E4: Unidentified Patient Assigned Temporary Departmental ID and Scheduled at DSS/Order Filler**

In this case, no valid Patient ID is available to the Department System Scheduler/Order Filler. It assigns a temporary Patient ID and a temporary name and schedules the required procedure.

**Note:** The Department System Scheduler/Order Filler must ensure that the assigned temporary Patient ID is unique within its scope.

The temporary Patient ID is conveyed to the Image Manager. When patient information becomes known, the ADT sends new patient information to both the Order Placer and the Department System Scheduler/Order Filler. The Department System Scheduler/Order Filler reconciles received patient information with that associated with the temporary Patient ID and merges the permanent patient record with its own temporary one and sends a Patient Update transaction to the Image Manager. At the same time, the Department System Scheduler/Order Filler generates and submits an order to the Order Placer using a permanent Patient ID.

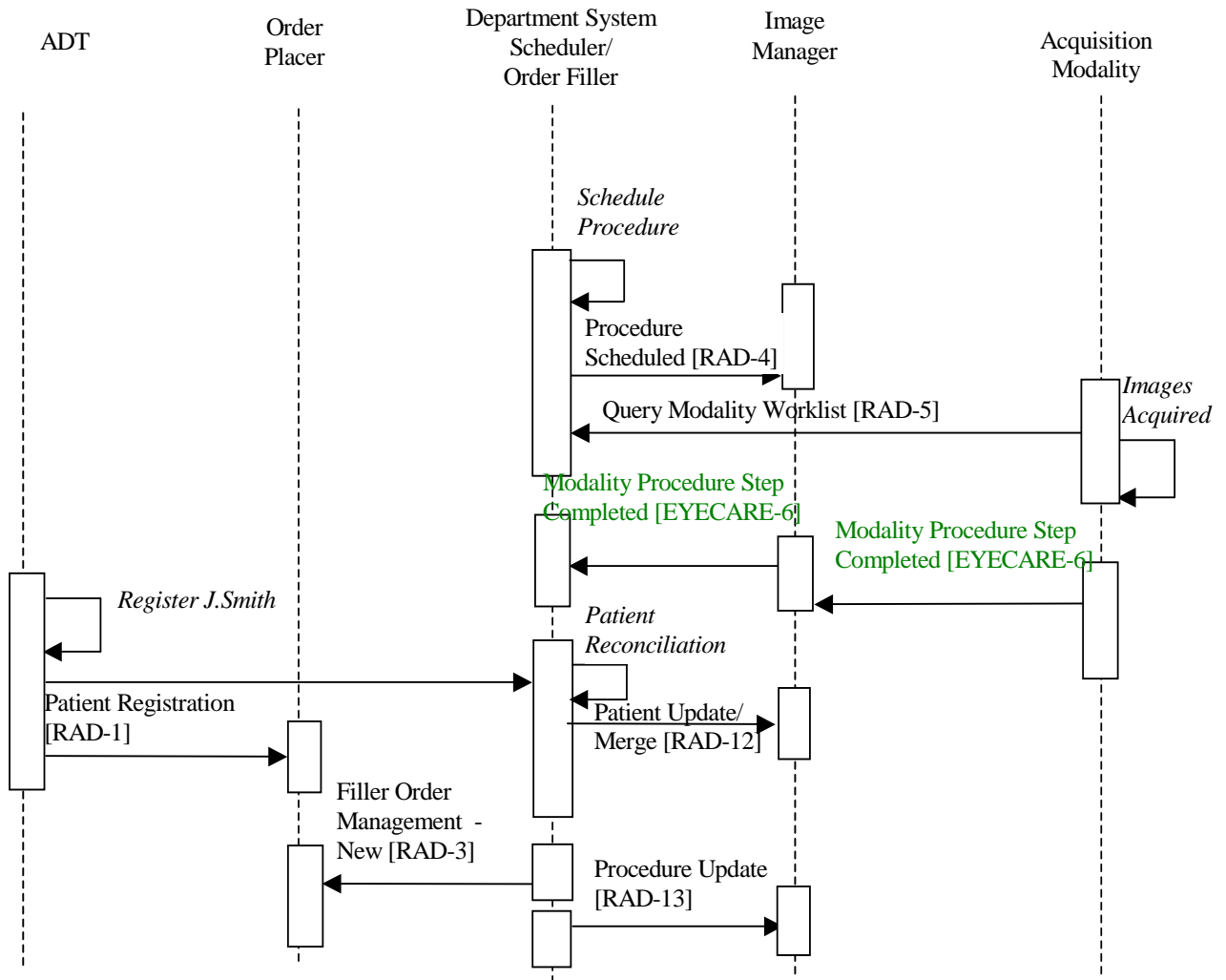

**Figure 3.6.6-1 Unidentified Patient– Case E4**

Significant Transactions:

- Patient information is reconciled internally by the Department System Scheduler/Order Filler using the Patient Registration from ADT.
- The Department System Scheduler/Order Filler sends the Patient Update [RAD-12] transaction to the Image Manager.
- The Department System Scheduler/Order Filler sends the Filler Order Management (New Order) transaction [RAD-3] to the Order Placer.

### **3.6.5 Case E5: Image Acquisition Completed Without Scheduling at Department System Scheduler/Order Filler**

In this case, no valid Patient ID is available to the Department System Scheduler/Order Filler and no scheduling is done before the procedure is performed. A temporary ID and name are entered by the operator at the Modality and conveyed to the Department System Scheduler/Order Filler and to the Image Manager. The Patient ID and name are selected by the operator according to the locally defined rules; for example, selected from the predefined pool of “Patient ID–patient name” pairs. The rules for selecting temporary Patient ID shall guarantee its uniqueness within the scope of Department System Scheduler/Order Filler.

Upon receiving the Modality Procedure Step Completed message, the DSS/OF and Image Manager recognize an unscheduled case based on the content of the message (absent or empty Referenced Study Sequence, see RAD TF-2, Appendix A). When patient information becomes known, the ADT sends the new patient information to both the Order Placer and Department System Scheduler/Order Filler. The Department System Scheduler/Order Filler performs a merge of the permanent patient record with the temporary one and sends a Patient Update to the Image Manager. At the same time, Department System Scheduler/Order Filler generates and submits an order to the Order Placer using a valid Patient ID.

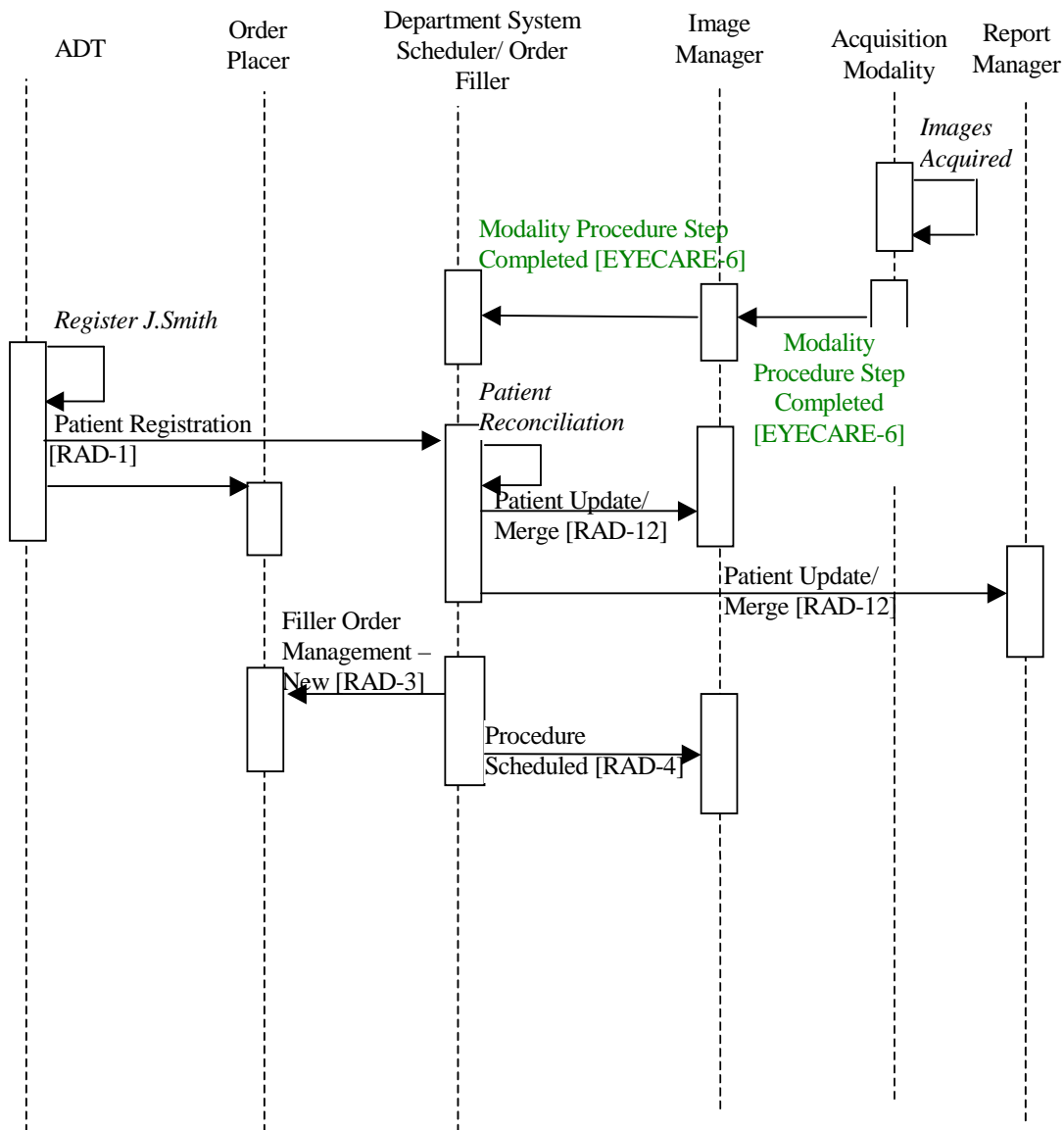

**Figure 3.6.7-1 Unidentified Patient – Case E5**

Significant Transactions:

- On receiving a Procedure Step Completed transaction, the Department System Scheduler/Order Filler recognizes it as an unscheduled case.
- Patient information is reconciled internally by the Department System Scheduler/Order Filler using the Patient Registration from the ADT.
- The Department System Scheduler/Order Filler sends a Patient Update (Merge) transaction to the Image Manager.

- The Department System Scheduler/Order Filler sends a Filler Order Management (New Order) transaction [RAD-3] to the Order Placer.
- Using the information from the Procedure Step Completed transaction and placed order, the Department System Scheduler/Order Filler creates a new Requested Procedure record and sends a Procedure Scheduled [RAD-4] transaction to the Image Manager.

### **3.6.6 Case E6: Patient Information Reconciliation During Image Acquisition**

Updates may need to occur after the initial Patient Registration and Order Placement has occurred. The Modality may have requested information from the Department System Scheduler before the update has occurred and continue to send the images with the original Patient Registration and Order information. The Image Manager will need to continue updating the patient information from items retrieved from the Image Archive.

#### Significant Transactions:

- The Modality may continue to send information using the original patient information even after the patient update has occurred.
- The Image Manager must continue reconciling Patient Information even after the Patient Update transaction has been completed.

Only partial transactions are shown. Other transactions are performed according to the profile requirements.

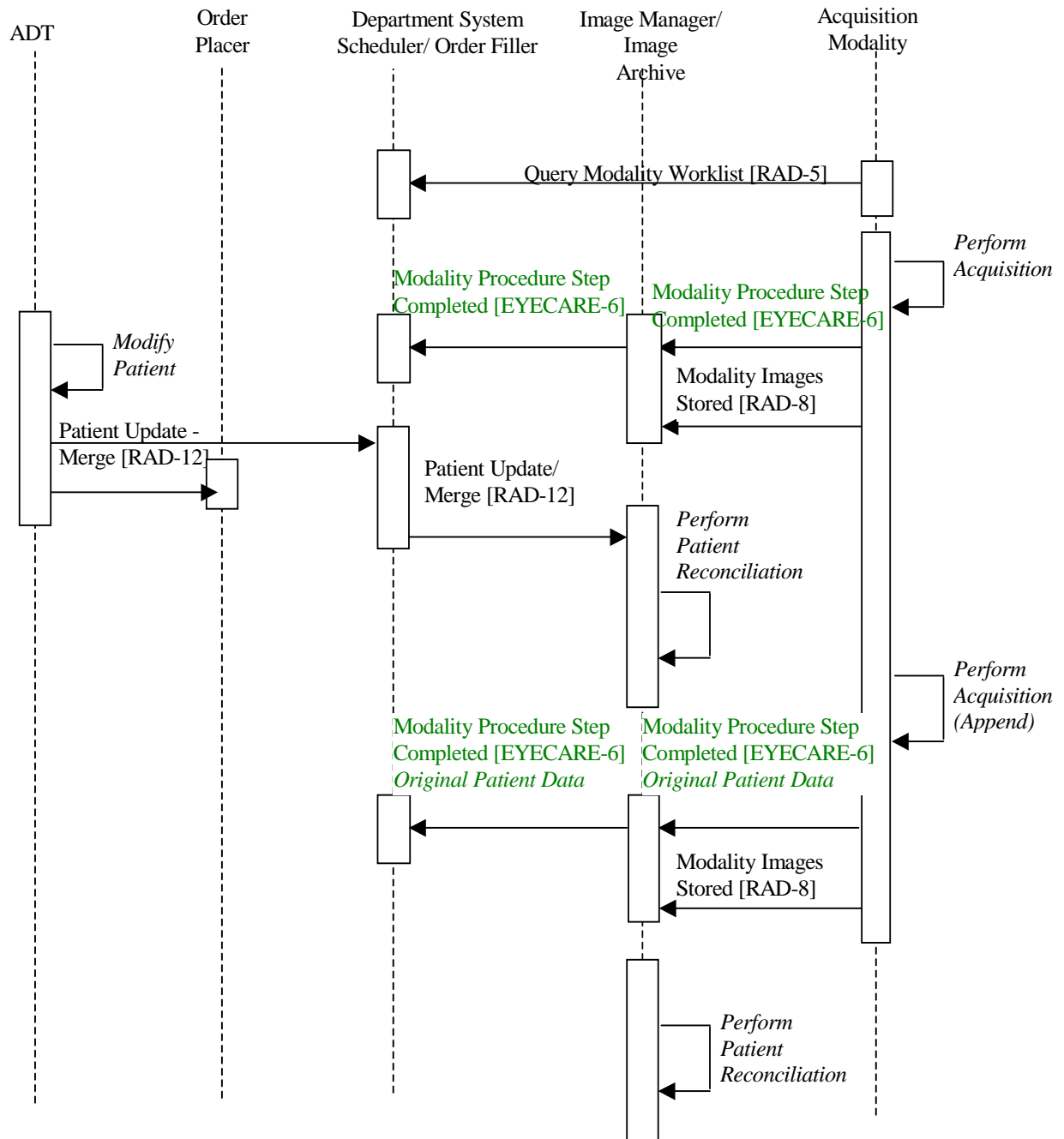

Figure 3.6.8-1 Patient Information Reconciliation During Image Acquisition

### 3.6.7 Case E7: Cancel Procedure

**Clinical Context:** When an eye care procedure is cancelled, it is important for the information systems to keep track of the cancellation.

**IHE Context:** This case describes the process flow for canceling a procedure prior to its start. The procedure is ordered by the Order Placer system, or by the DSS/OF, as shown in Figure 3.6-8. The DSS/OF assigns the Requested Procedure ID and Study Instance UID, schedules the procedure, and notifies the Image Manager.

If the procedure is cancelled in the department, the DSS/OF notifies the Order Placer system and the Image Manager. All three systems - DSS/OF, Order Placer, and Image Manager – may maintain information about the cancelled Order and Requested Procedure for an implementation- or institutionally-determined length of time.

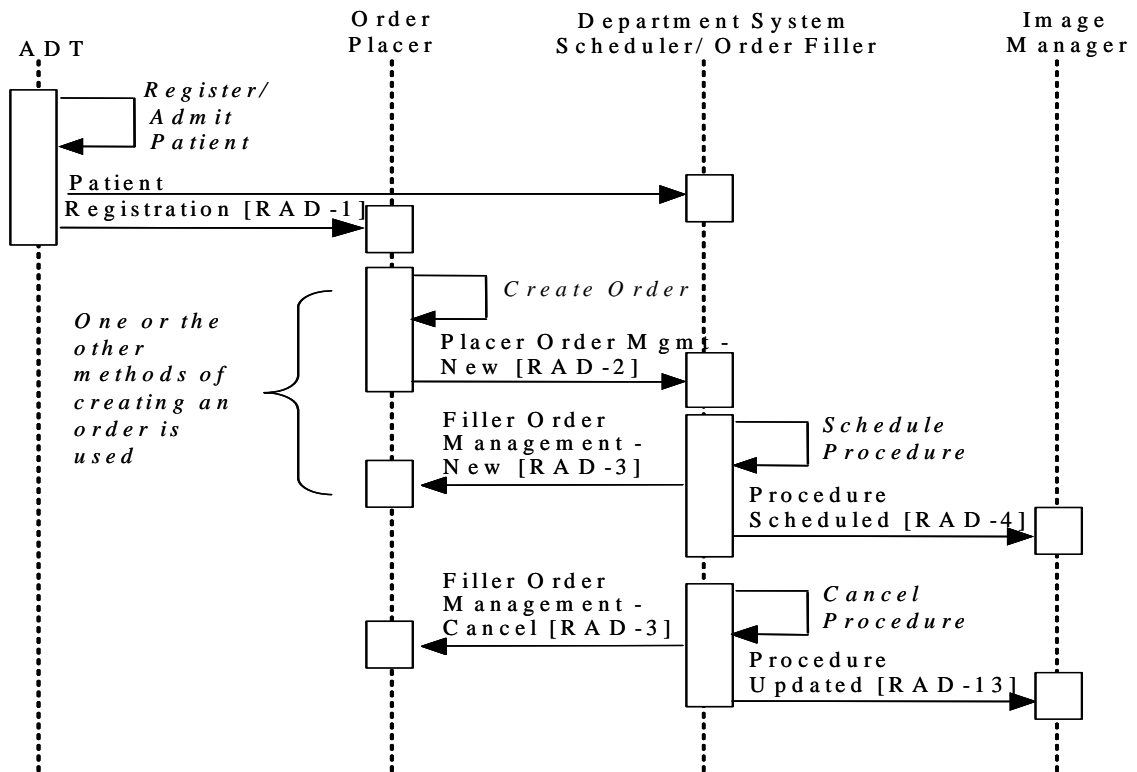

Figure 3.8.9-1 Cancel Procedure – Case E7

## 4 Eye Care Charge Posting (EC-CHG)

The Eye Care Charge Posting Integration Profile describes mechanisms to transfer charge information to the clinic or enterprise Charge Processing System. This section corresponds to Transaction RAD-35 of the IHE Technical Framework. Transaction RAD-35 is used by the Department System Scheduler/Order Filler and Charge Processor actors. This section also refers to RAD-36 of the IHE Radiology Technical Framework that is used by the ADT Patient Registration and Charge Processor Actors. This section will correlate the activities that occur in the eye care clinic with these IHE defined transactions. The standards used are Health Level Seven, Version 2.3.1: Chapter 6 - Financial Management and DICOM 2007 PS 3.4 Modality Performed Procedure Step SOP Class.

### 4.1 Actor/Transactions

The actor names are defined below.

Note: Eye Care Charge Posting as used by The Eye Care Domain currently covers the area of billing for procedure acquisition information. The defined Radiology profile supports these plus additional charges for professional reports, etc. Future versions of the IHE Eye Care TF will also address professional reports, etc., very likely just as defined by Radiology. However, since it is not in this version, this is not formally defined.

**Acquisition Modality** – A system that acquires and creates medical images while a patient is present. A modality may also create other evidence objects such as Grayscale Softcopy Presentation States for the consistent viewing of images or Evidence Documents containing measurements, etc. In eye care, modalities acquire diagnostic information such as images and/or evidence documents. Some examples of these may include photography, topography, refractive exams, corneal and retinal topography, visual fields, etc. The Acquisition Modality is responsible for returning performed protocol code information as part of Eye Care Workflow.

**ADT Patient Registration** – A system responsible for adding and/or updating patient demographic and encounter information. In particular, it registers a new patient with the Department System Scheduler/Order Filler and the Charge Processor. In eye care, an ADT system is commonly called a Practice Management System.

**Department System Scheduler/Order Filler** – A department-based system that provides functions related to the management of orders received from external systems or through the department system's user interface. An eye care example of a department based system could be an Eye Care Electronic Health Record (EHR). The Department System Scheduler/Order Filler system sends charges to the Charge Processor.

**Charge Processor** – It processes and combines charges in order to issue an insurance claim or patient's billing statement. An eye care example could be a Practice Management System.

**Performed Procedure Step Manager** – A system that re-distributes the Modality Performed Procedure Step information from the Acquisition Modality to the Department System Scheduler/Order Filler and Image Manager.

Figure 4.1-1 diagrams the actors involved with the Eye Care Charge Posting profile and the transactions between actors. The **transactions** denote changes from the Radiology workflow.

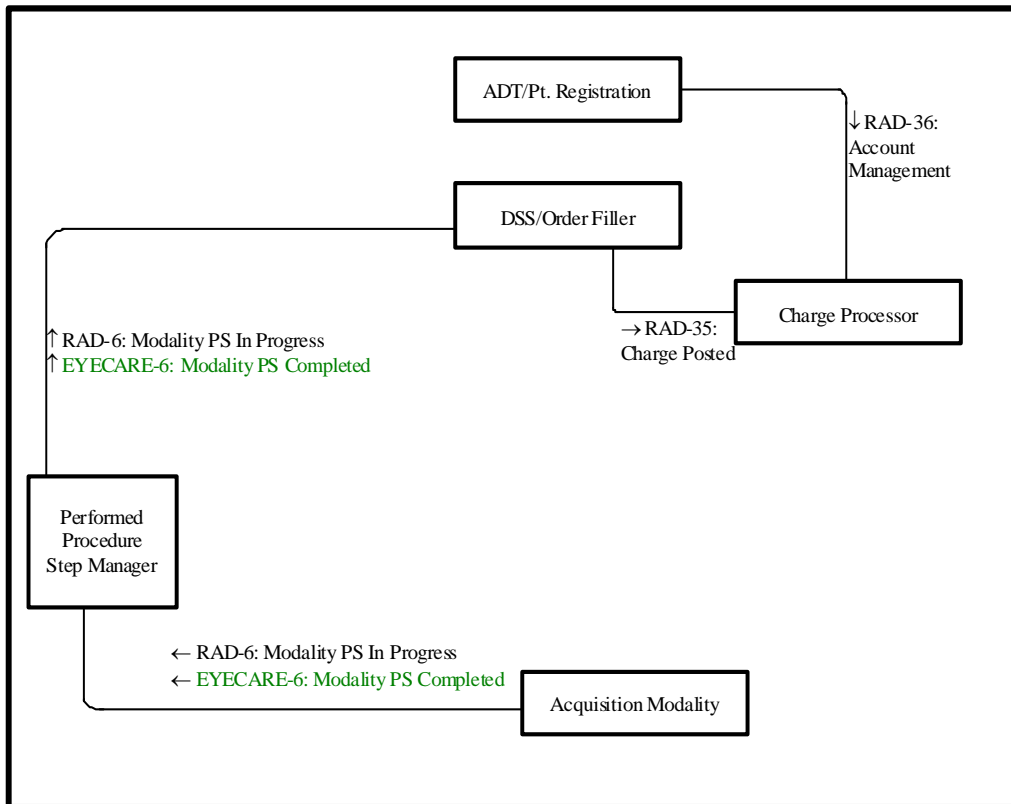

**Figure 4.1-1. Eye Care Charge Posting Transaction Diagram**

Table 4.1-1 lists the transactions for each actor directly involved in the Eye Care Charge Posting Profile as used by the Eye Care Domain. In order to claim support of this Integration Profile, an implementation must perform the required transactions (labeled “R”). Transactions labeled “O” are optional.

**Table 4.1-1. Charge Posting – Actors and Transactions**

Actors	Transactions	Optionality	Section
ADT Patient Registration	Account Management [RAD-36]	R	RAD-TF 3: 4.36
Department System Scheduler/	Charge Posted [RAD-35]	R	RAD-TF 3: 4.35

Actors	Transactions	Optionality	Section
Department System Scheduler/Order Filler/Performed Procedure Step Manager	Modality Procedure Step In Progress [RAD-6]	R	RAD-TF 2: 4.6
	Modality Procedure Step Completed [EYECARE-6]	R	EYECARE-TF 2: 4.6
Acquisition Modality	Modality Procedure Step In Progress [RAD-6]	R	RAD-TF 2: 4.6
	Modality Procedure Step Completed [EYECARE-6]	R	EYECARE-TF 2: 4.6
Charge Processor	Charge Posted [RAD-35]	R	RAD-TF 3: 4.35
	Account Management [RAD-36]	R	RAD-TF 3: 4.36

Refer to Table 2-1 for other profiles that may be pre-requisites for this profile.

## 4.2 Eye Care Charge Posting Integration Profile Options

Options that may be selected for this Integration Profile are listed in the table 4.2-1 along with the Actors to which they apply. Dependencies between options when applicable are specified in notes.

**Table 4.2-1 Eye Care Charge Posting – Actors and Options**

Actor	Options
ADT Patient Registration	<i>No options defined</i>
Department System Scheduler/ Order Filler	<i>No options defined</i>
Acquisition Modality	<i>No options defined</i>
Performed Procedure Step Manager	<i>No options defined</i>
Charge Processor	<i>No options defined</i>

### 4.3 Eye Care Charge Posting Process Flow

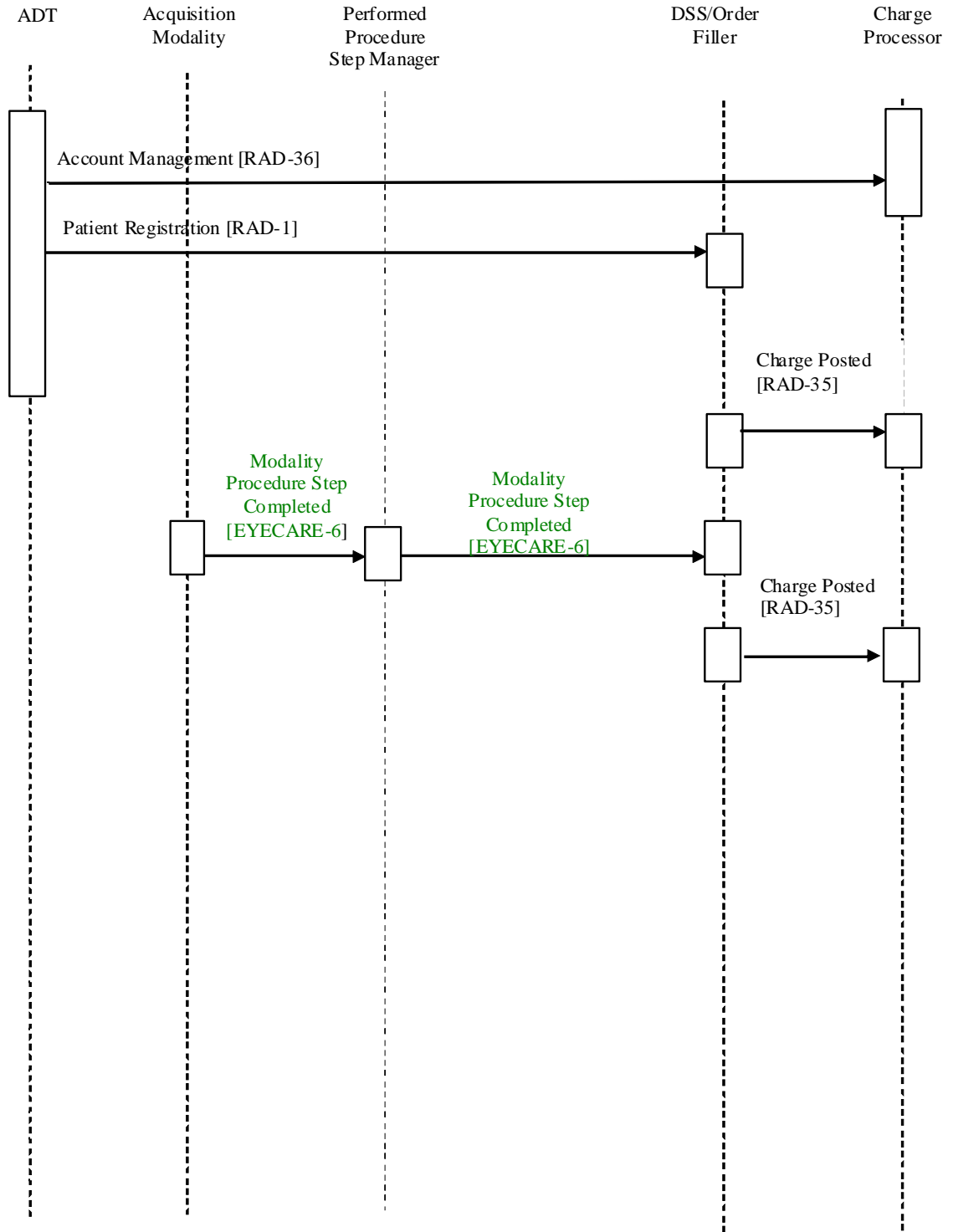

Figure 4.3-1 Eye Care Charge Posting Process Flow

Events that may trigger a charge posted transaction are Procedure Ordered, Procedure Scheduled, and Procedure Completed.

### **4.3.1 Use Cases**

This section describes the potential use cases relating to the charge posting functionality. It is the responsibility of the Department System Scheduler/Order Filler to ensure that the billing information is sent to the Charge Processor. The Department System Scheduler/Order Filler forwards the data that is required by the Charge Processor to generate the claim.

The Charge Processor shall accept the Charge Posted Transaction information. Interpretation and subsequent billing processes by the Charge Processor are beyond the scope of this profile.

Below are two use cases for Eye Care.

### **4.3.2 Eye Care Uses Cases for Technical Billing (Procedure Billing)**

#### **4.3.2.1 New Patient Appointment**

A new patient calls and makes an appointment for a visit. The patient arrives at the clinic on the date scheduled. The front desk clerk asks the new patient to fill out the rest of their demographics and insurance information on a standard paper form. The clerk accepts completed documents and enters the information into the ADT Patient Registration. The registration system validates the information and distributes the necessary demographics information to the Department System Scheduler/Order Filler system. The patient is then led through a series of rooms where standard tests are usually performed on new patients. These tests could include non-mydratic fundus photos, refraction, topography, pachymetry, and vision exams. A technician normally performs these tests. The patient is then taken to a room to be seen by the healthcare provider. The healthcare provider will normally perform an external eye, a slit-lamp biomicroscopic and a fundus exam. The healthcare provider may then perform additional examinations and/or procedures that may include gonioscopy, extended sensorimotor exam, removal of foreign bodies, insertion of plugs, application of eye patches, protective contact lenses, etc.

After the above procedures are completed, the Acquisition Modality transmits the Modality Performed Procedure Step Completed [EYECARE6] as shown in figure 4.3-1. This transaction includes the Performed Protocol Code Sequence which provides the DSS/OF the needed information to map the protocols to the procedures and CPT codes to automatically send charges to the Charge Processor.

If additional tests that require the use of diagnostic and/or imaging devices (modalities) are required, then an order will be created and the patient will be scheduled for those tests in Department System Scheduler/Order Filler. The patient will arrive at the department responsible for filling the orders issued by the healthcare provider. The technician will perform the diagnostic procedures on the patient using the specified modality. When the diagnostic procedures have been completed, the DSS/Order Filler will automatically send the new charges to the Charge Processor.

#### **4.3.2.2 Existing Patient**

The patient is scheduled for an exam that involves a specific test like a visual field. This test has been ordered by the healthcare provider at a previous point in time, which in many cases is not even the same day. The healthcare provider may not see the patient the day that the test is completed. A technician will complete the test. The Department System Scheduler/Order Filler will receive a procedure completed message from the modality that includes the actual protocol performed. The Department System Scheduler/Order Filler will send the charges for the technical portion of the billing to the Charge Processor. The healthcare provider will review the procedure results and the Department System Scheduler/Order Filler will send the professional fee charges to the Charge Processor.

Note: Professional billing will be addressed in the future.

### **4.4 Data Model for Eye Care Charge Posting**

The data model adopted by the IHE Technical Framework for the HL7 messages used in the Eye Care Charge Posting Profile is based on a subset of HL7 2.3.1 as described in section 4.3.1.

#### **4.4.1 Model of the Real World**

Figure 4.4-1 depicts the model of the real world within scope of the Eye Care Charge Posting Profile. This model corresponds to the approach suggested in the HL7 standard, in particular:

- Financial data related to the patient are accumulated as properties of accounts. A patient may have more than one active (open) account at a time.
- One account may contain financial data pertaining to more than one Visit. A visit, however, cannot span multiple accounts.
- There may be multiple Billable Procedures performed and multiple charges posted as a result of one visit. There may be one charge posted for multiple procedures and one procedure to be charged in multiple charge postings.
- Requested Procedures may be Billable Procedures. One Requested Procedure may correspond to more than one Billable Procedure.

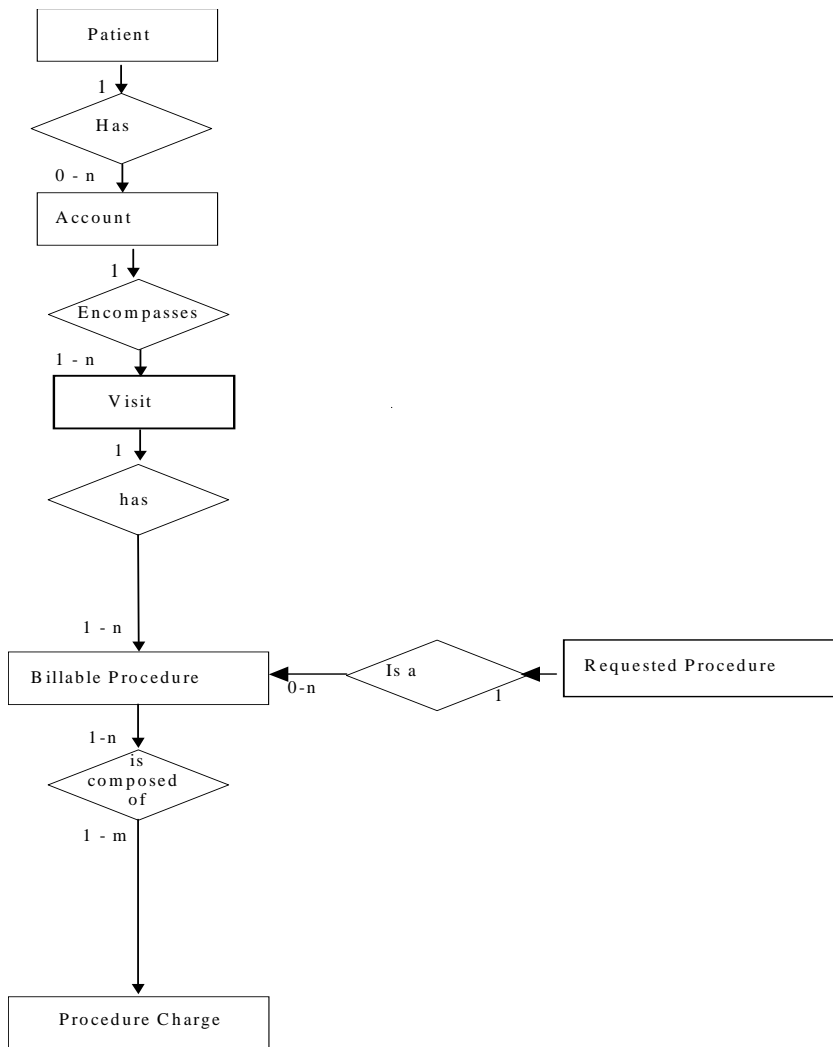

## 5 Eye Care Evidence Documents (ECED)

The Eye Care Evidence Documents Profile defines information such as observations, measurements, and results (i.e., evidence documents), to be output by devices, such as acquisition systems and other workstations; to be stored and managed by archival systems; and to be retrieved and presented or used by display and reporting systems.

This allows detailed non-image information, such as measurements, post processing, etc. to be made available as input to the process of generating a clinical Report, either as additional evidence for the reporting healthcare provider, or in some cases for selected items in the Evidence Document to be included in the report.

The full specification of the Evidence Documents Profile is found in **RAD-TF 1:14**. This section adds the eye care specific options for that definition. The main extension for eye care is the use of DICOM Encapsulated PDF.

Note: As of this version, DICOM WG 9 is in the process of defining DICOM IODs to convey such information. For procedures that are not defined in DICOM this framework allows for the use of DICOM Encapsulated PDF to convey such information. Once DICOM supports DICOM IODs for such evidence documents, Actors will be required to additionally support eye care specific DICOM IODs

Note: The DICOM standard does not define use of a specific version of PDF when encapsulated PDF is used. This may result in incorrect display of reports when using a different PDF version of software from that which was used to create the files. Other issues arise when using only PDF with pixel data as the files are large and have difficulties with display. IHE EYECARE defines specific versions required for support see EYECARE TF2: 4.2.

### 5.1 Actors/Transactions

Figure 5.1-1 shows the actors directly involved in the Evidence Documents Profile and the relevant transactions between them.

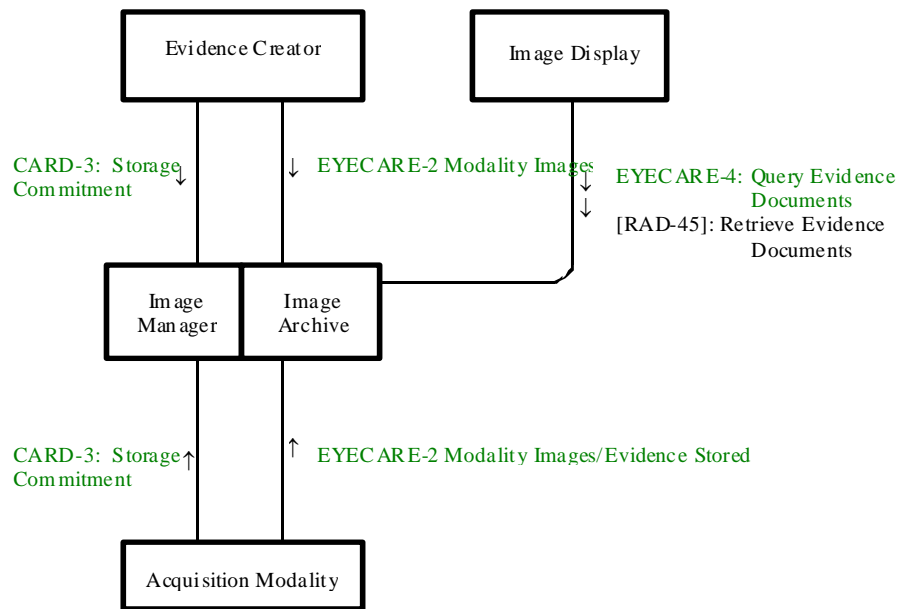

**Figure 5.1-1. Evidence Documents Actor Diagram**

Table 5.1-1 lists the transactions for each actor directly involved in the Eye Care Evidence Documents Profile. In order to claim support of this Integration Profile, an implementation must perform the required transactions (labeled “R”). Transactions labeled “O” are optional. A complete list of options defined by this Integration Profile and that implementations may choose to support is listed in Volume I, Section 5.2.

**Table 5.1-1. Evidence Document Integration Profile - Actors and Transactions**

Actors	Transactions	Optionality	Section
Evidence Creator	Storage Commitment [CARD-3]	R	CARD-TF 2: 4.3
	Modality Images/Evidence Stored [EYECARE-2]	R	EYECARE-TF 2: 4.2
Acquisition Modality	Storage Commitment [CARD-3]	R	CARD-TF 2: 4.3
	Modality Images/Evidence Stored [EYECARE-2]	R	EYECARE-TF 2: 4.2
Image Manager/ Image Archive	Storage Commitment [CARD-3]	R	CARD-TF 2: 4.3
	Modality Images/Evidence Stored [EYECARE-2]	R	EYECARE-TF 2: 4.2
	Query Evidence Documents [EYECARE-4]	R	EYECARE-TF 2: 4.4
	Retrieve Evidence Documents [RAD-45]	R	RAD-TF 3: 4.45

Image Display	Query Evidence Documents [EYECARE-4]	R	EYECARE-TF 2: 4.4
	Retrieve Evidence Documents [RAD-45]	R	RAD-TF 3: 4.45

## 5.2 Evidence Documents Profile – EYE CARE Options

The Options defined for the Eye Care domain that may be selected for this Integration Profile are listed in the table 5.2-1 along with the Actors to which they apply.

**Table 5.2-1 Evidence Documents - Actors and Options**

Actor	Options
Evidence Creator	<i>No options defined</i>
Acquisition Modality	<i>No options defined</i>
Image Manager/ Image Archive	<i>No options defined</i>
Image Display	<i>No options defined</i>

The Evidence Creator, Acquisition Modality and Image Manager/ Image Archive will likely support a variety of DICOM SOP Classes. Each DICOM SOP Class that is supported by the actor shall be listed in the product’s DICOM Conformance Statement.

Note: The minimum set of DICOM SOP Classes that must be supported by eye care actors are defined in IHE Eye Care Volume 2 (see EYECARE TF2: 4.2).

## 5.3 Eye Care Evidence Document Process Flow

Evidence Documents belong to the family of Evidence Objects such as measurements, post processing, images, presentation states, DICOM Structured Reports, etc. These are objects generated as a result of creating eye care diagnostic information after the patient has left the acquisition stage of the procedure.

As with other Evidence Objects, Evidence Documents are used in the process of creating a Diagnostic Report, either by reviewing or interpreting the Evidence Document contents, or by copying selected parts into the Report. Evidence Documents represent the uninterrupted information that is primarily managed and used inside an eye care department, although distribution outside the department is not precluded.

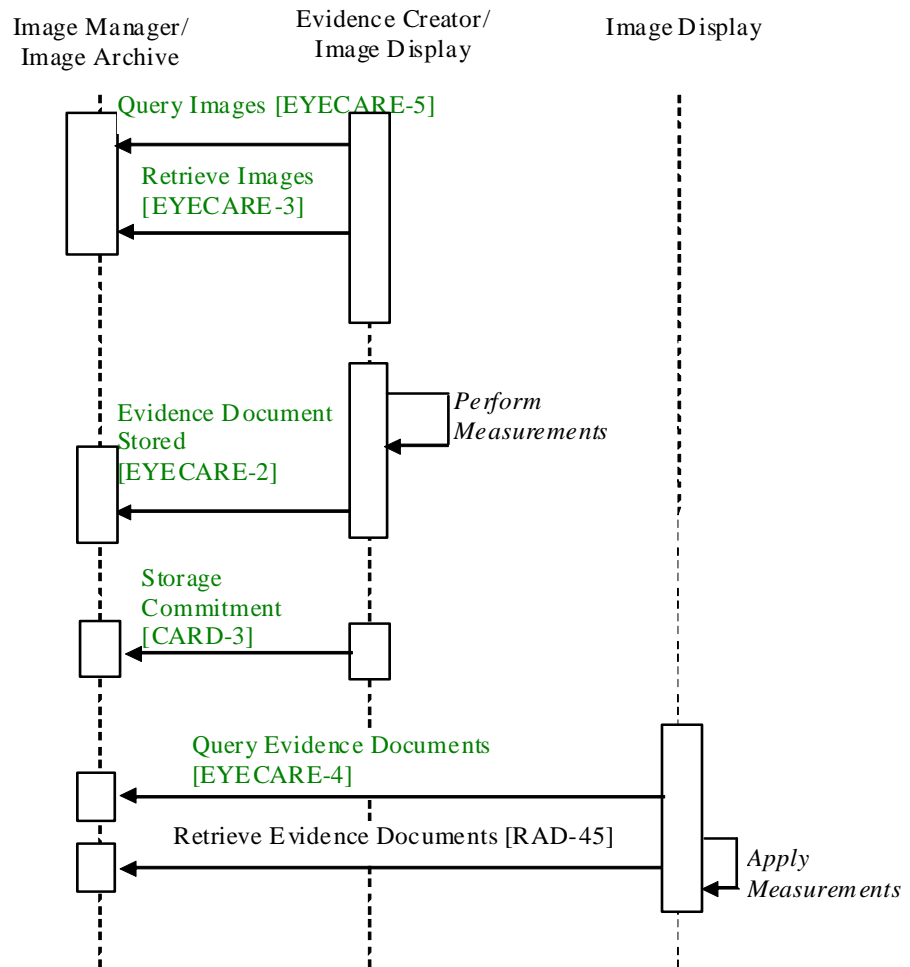

Figure 5.3-1. Eye CARE Evidence Document Workflow Example

## 5.4 Eye Care Evidence Documents Use Cases

This section describes the specific use cases defined for the Eye Care Evidence Documents Profile.

### 5.4.1 Eye Care Evidence Documents Being Created by Acquisition Modality

A typical use case for evidence documents include them being generated at the Acquisition Modality. A technician performs the acquisition, and the instrument performs implicit post-processing immediately following the acquisition. This may be entirely automatic, or require limited user inputs. An example is glaucoma progression analysis performed on visual field analyzers, or the RNFL analysis performed on an OPT device. The instrument provides the

evidence document at the end of the acquisition cycle. The transaction diagram for this use case is already in Eye Care Workflow Integration Profile.

#### **5.4.2 Eye Care Evidence Documents Being Created by Workstations**

This use case describes unscheduled post-processing done after the acquisition has completed. A few examples include a workstation using review software, an EHR system, etc. The post-processing software performs as an image display actor and evidence creator actor. The user is often a healthcare provider. Examples are measurements on fundus images, corneal ablation planning based on corneal topography maps, or measurements on anterior chamber OCT images for phakic IOL implantation planning. The Evidence Creator actor (i.e. post-processing software) may perform queries and retrieves in order to obtain images and other evidence documents. For example, if previous measurements were done, these may be retrieved and used as an input for making more refined measurements. Once the post-processing is completed, the images and/or evidence documents are sent to the Image Archive for storage and the ownership of the objects are handed off to the Image Archive using Storage commitment.

Note: A workstation and/or acquisition modality supporting the Eye Care Evidence Document profile may perform a single query to obtain information about both images and evidence documents (i.e. two queries are not required). Similarly, when retrieving the information, one retrieve could be used to obtain both images and evidence documents.

## 6 Eye Care Displayable Report (ECDR)

The Displayable Reports Profile specifies transactions supporting the creation, query/retrieve, and reading of display-ready eye care reports. The ECDR Profile allows use of the DICOM Encapsulated Document IOD, which has emerged as a ubiquitous means of encoding documents ready for presentation, including graphical content. Furthermore, the ECRD Profile allows the reporting healthcare provider to control the “look” of the report, which is important for both clinical and business reasons.

Note: The types of Encapsulation documents supported are defined in EYECARE TF:2 4.7, such as DICOM Encapsulated PDF SOP Class.

Note: The DICOM standard does not define use of a specific version of PDF when encapsulated PDF is used. This may result in incorrect display of reports when using a different PDF version of software from that which was used to create the files. Other issues arise when using only PDF with pixel data as the files are large and have difficulties with display. IHE EYECARE defines specific versions required for support see EYECARE TF2: 4.7.

### 6.1 Actors/Transactions

Figure 6.1-1 diagrams the actors involved with this profile and the transactions between actors.

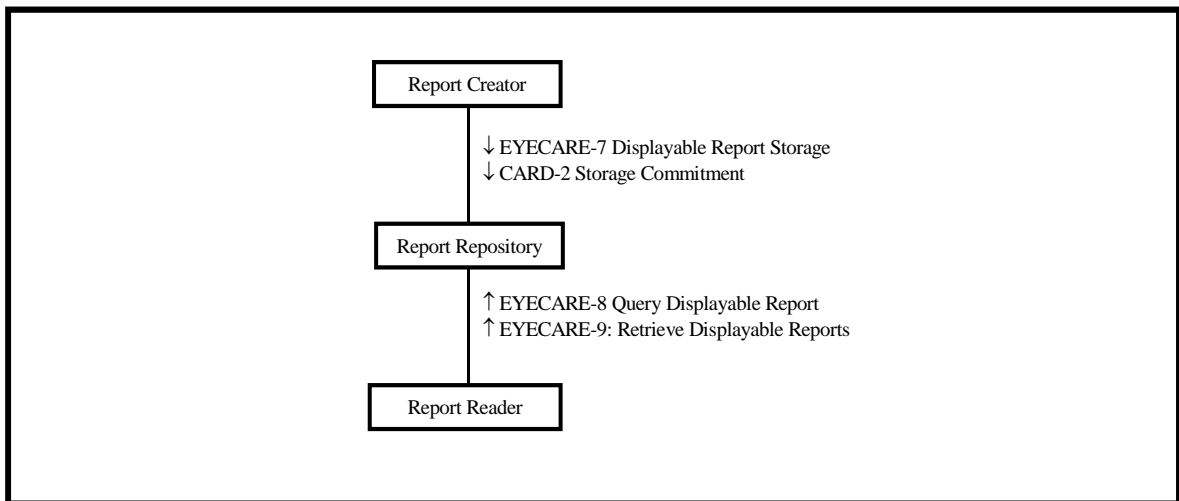

Figure 6.1-1. Eye Care Displayable Report Diagram

Table 6.1-1 lists the transactions for each actor directly involved in the Eye Care Displayable Report Integration Profile. In order to claim support of this Integration Profile, an implementation must perform the required transactions (labeled “R”). Transactions labeled “O” are optional. A complete list of options defined by this Integration Profile and that implementations may choose to support is listed in Volume I, Section 6.2.

**Table 6.1-1. Eye Care Displayable Report - Actors and Transactions**

Actors	Transactions	Optionality	Vol II / III Section
Report Creator	Displayable Report Storage [EYECARE-7]	R	EYECARE-TF 2: 4.7
Report Reader	Query Displayable Reports [EYECARE-8]	R	EYECARE-TF 2: 4.8
	Retrieve Displayable Reports [EYECARE-9]	R	EYECARE-TF 2: 4.9
Report Repository	Displayable Report Storage [EYECARE-7]	R	EYECARE-TF 2: 4.7
	Query Displayable Reports [EYECARE-8]	R	EYECARE-TF 2: 4.8
	Retrieve Displayable Reports [EYECARE-9]	R	EYECARE-TF 2: 4.9

## 6.2 Eye Care Displayable Report Integration Profile Options

Options that may be selected for this Integration Profile are listed in the table 6.2-1 along with the Actors to which they apply. Dependencies between options when applicable are specified in notes.

**Table 6.2-1. Eye Care Displayable Report - Actors and Options**

Actor	Options
Report Creator	<i>No options defined</i>
Report Reader	<i>No options defined</i>
Report Repository	<i>No options defined</i>

The Report Creator and Report Repository will likely support a variety of DICOM SOP Classes. It is expected that this level of optionality will be documented by a reference in the IHE Integration Statement (see appendix D).

## 6.3 Eye Care Displayable Report Use Case

This section describes the specific use cases defined for the Eye Care Displayable Reports Profile.

### 6.3.1 Typical Displayable Report Example

The healthcare provider is monitoring the progress of a patient who was diagnosed with glaucoma two years ago. The patient is in the clinic for a 3-month intraocular pressure check. During the physical exam in the clinic it is determined that the intraocular pressure in the right eye is slightly elevated. The healthcare provider orders a Visual Field Test for both eyes. The patient has not had this test performed in the past twelve months and is scheduled for it. The Visual Field department notifies the healthcare provider when the Visual Field test is completed and ready to be interpreted. Automated workflow notification processing is out of the scope of this Report Creation profile. The Visual Field Modality produces an image that contains analytical metrics and a diagram of the patient's peripheral vision blind spots. The healthcare provider performs a query/retrieve to obtain the new images. In order to determine if the damage is consistent with what existed the last time this diagnostic test was done, the healthcare provider query/retrieves the Visual Field image that was created twelve months ago. The healthcare provider compares the images, usually in a side-by-side display. The healthcare provider's findings are explained in an interpretation narrative that is saved in the encapsulated document object. The plan for continued treatment is also described in the encapsulated document. The encapsulated interpretation document is stored in the Report Repository. The healthcare provider verifies the encapsulated interpretation DICOM object.

## **The Eye Care Workflow Procedure in Perspective**

### **Appendix A: Challenges of Workflow Management in Eye Care**

#### **A.1 Clinical Context – Patient Encounter in an Independent Practice**

In Eye Care, patients present with a variety of symptoms and complaints, which may or may not result in the need for diagnostic imaging and testing. Some types of imaging and testing may be performed routinely, before patients are seen by a healthcare provider. Other types of imaging and testing may be performed only after a healthcare provider has determined the need for them while examining the patient. Thus orders may be placed either manually by a healthcare provider or automatically by the DSS/OF. The automatic orders may or may not be completed based upon clinical need. This requirement of flexibility is paramount.

Orders may be modality specific, e.g., a Visual Field machine is used to produce a Visual Field; a B-Scan ultrasound device produces an ultrasound image, etc. However, the result of one test may indicate a need for additional testing and evaluation to make a diagnosis, or determine an appropriate management plan. Additionally, some tests are performed preparatory to a procedure after the diagnosis is made. The ordering process is just not often structured and the need for flexibility while maintaining accuracy is paramount.

#### **A.2 The Current Workflow**

In even the best eye care practices, there is currently potential for error and inefficiency because of the multitude of players in a practice. Consider a practice that has an electronic health record (EHR) system, a practice management system (PMS) and numerous types of devices/instruments for diagnostic purposes.

For example, a potential patient calls the practice for an appointment, either because they have a concern about their eyes/vision, or because another practitioner has discovered a problem and suggested a consultation or a procedure. If another healthcare provider refers the patient and the referring healthcare provider makes the appointment, then a reasonable amount of information is transferred from the referring healthcare provider to the healthcare provider that is going to see the patient, although this is not the most common scenario. If the patient calls, usually a minimum of patient information is retrieved from the phone call and entered into the PMS. An appointment is scheduled, usually in the PMS, although occasionally the scheduling function is handled by the EHR or a separate scheduling application.

When the patient arrives at the clinic, additional information is entered into the PMS system and forms are filled out and signed. At this time the clinic has all the necessary information so the healthcare provider and/or staff can see the patient. The information gathered at this point becomes available to the rest of the information systems and devices in the IHE practice. Under the most optimized of non-IHE practices, this information would flow from the PMS to the EHR and potentially to each device/equipment as a result of a specific custom interface written. In the case where the information isn't available automatically, patient information is re-entered by hand

by the technician into the device or application that is going to be used to help diagnose the patient.

After completion of paperwork, the patient is taken to a work up area by a technician, who will perform initial tests and measurements based on the type of exam that has been requested and on the complaints of the patient. Results are entered into the EHR, either by hand, or through a custom interface from some diagnostic equipment (e.g., auto refractors, lensometers). The healthcare provider is directed to the readied patient and arrives to examine the patient.

After initial review and evaluation, the practitioner may choose to have one or more tests performed, either immediately or at a later time. This is often expressed verbally to a technician, particularly if it is to be done in the office that day. The technician or the scribe may enter the order for a test into the EHR system. This increases accountability, but still leaves room for error and provides no real means for reporting back, other than the arrival in the EHR of the resulting test data or image.

The patient is then sent or guided to the diagnostic technician. In the integrated, but non-IHE environment, there will likely be an EHR workstation in the technician's area to indicate the healthcare provider's order and to capture the result. In the non-EHR office, the chart travels with the patient and the documents are added to the stack, or the fact that the images are available in the storage repository of the diagnostic device is recorded. The practitioner is then informed that the test is done. The healthcare provider reviews and documents the interpretation of the results of the tests and makes an assessment, or decides that additional testing is needed and orders those tests. Once all testing and interpretation have been completed, the practitioner reviews the total exam, documents all relevant diagnoses, including the primary diagnosis, and reviews the findings and proposed plan with the patient. A final plan is produced and documented, and needed communications are generated, usually in the form of reports and/or letters to referring healthcare providers and the patient.

## **A.3 Workflow Example using Automatic Orders**

### **A.3.1 The Use Case**

A patient pre-registers in a clinic over the phone. An appointment is created for a future date, the patient selects a healthcare provider and the registration person finds an open slot in that healthcare provider's schedule.

The clinic has a protocol defined for patient visits that involves several diagnostic procedures. These diagnostic procedures are designed to give the healthcare provider base line information about the patient's general ophthalmic health. The ophthalmic technician normally performs these diagnostic tests. The types of tests done may vary from clinic to clinic and many possible examples include:

- An objective or auto-refraction device is commonly employed to create a starting point for the patient's refraction
- A Lensometer device will measure the patient's existing corrective glasses

- A Keratometer, Topographer, Wavefront, and Pachymeter may be used to measure the shape and thickness of the cornea
- One or several baseline fundus photos are taken with a non- mydriatic camera
- A manifest refraction on an all-in-one refraction station device
- Others...

### **A.3.2 Example of how IHE Could Be Used for this Use Case**

The Order Placer and DSS/OF is notified by the ADT/Patient Registration system that this patient has been registered and will generate the appropriate orders for a new patient visit. This would be accomplished using an A05 Pre-Registration ADT message and an A04 Outpatient Registration message. This list of orders is clinic defined and will be different from clinic to clinic. HL7 ORM messages are used to convey the orders between the Order Placer and DSS/OF.

The DSS/OF creates the device specific Acquisition Modality Worklists automatically (i.e. no user interface needed) in response to the ADT messages for a Patient Visit. The DSS/OF creates an HL7 ORM message and conveys this to the Order Placer and also makes these Acquisition Modality Worklists available to the Acquisition Modalities (via DICOM MWL) at the time the patient arrives in the clinic, (triggered by an A04 Out-Patient Registration ADT message) or based upon the scheduled appointment time. This would typically be the choice of the clinic.

After each Acquisition Modality performs its function, it conveys a DICOM MPPS back to the DSS/OF with the appropriate protocol information filled in (i.e. it lets the DSS/OF know it completed its job and identifies the actual protocol performed on its system). Now the DSS/OF knows exactly what was performed for this patient from each device that was used.

Not all of the Scheduled Procedure Steps will be performed for all patients all of the time for these Automatic Orders. For instance the Lensometer that measures the patient's glasses will not be used for someone who does not wear glasses. The DSS/OF is responsible to remove all unused worklist items that have not been performed on this patient. The triggering mechanism for removing these automatic orders from the device specific Acquisition Modality Worklists will be defined by the DSS/OF and configured for the specific needs of the clinic. This is outside the scope of IHE.

Note: Some examples could be, the ADT\Patient registration notifies the DSS/OF that the patient has been discharged from the clinic and that information can be used to remove any unused Modality Worklist Items for this patient that have not been fulfilled. The DSS/OF could also expire these items some time beyond the scheduled appointment date for that patient or the clinic could require human intervention to notify the DSS/OF to expire these items, or all of the above.

### **A.3.3 Continued Use Case Example With Manual Orders**

The patient sees the healthcare provider after all necessary automatic orders are completed. The healthcare provider reviews the results of the diagnostic tests that have been completed and then performs a physical exam of the patient. The healthcare provider may determine that further

testing is required, for example the healthcare provider see signs of Diabetic Retinopathy and orders Fluorescein Angiography Fundus Photos to document the locations that are bleeding.

A new order is created (i.e. in the Order Placer and an ORM message is created to notify the DSS/OF to schedule the additional tests). The DSS/OF associates the order with one or more Requested Procedures that have to be performed to satisfy the order. These procedures scheduled would most likely be very specific, as the healthcare provider has determined exactly what needs to be performed on the patient.

Each Requested Procedure prescribes a number of actions that have to be performed by an Acquisition Modality. Actions are specified in Scheduled Procedure Steps (SPS) based on timing and sequencing, and on modality. Scheduled Procedure Steps are scheduled, i.e., assigned a time slot and performing resource (modality), and are made available via DICOM MWL.

After each Acquisition Modality performs its function, it conveys a DICOM MPPS back to the DSS/OF with the appropriate protocol information filled in (i.e. it lets the DSS/OF know it completed its job and identifies the actual protocol performed on its system). Now the DSS/OF knows exactly what was performed for this patient from each device that was used.

The unfulfilled procedure steps for these manually scheduled items will most likely be removed by human action, but again this is outside the scope of IHE and up to the clinic. The clinic can be configured to direct the DSS/OF to send charges to the Charge Processor based on information obtained from the Acquisition Modality that, in this case, is the Fundus Photography Device.

## **Appendix B: The Eye Care Procedure in Perspective**

It is important to understand the scope of the portion of eye care workflow that is being addressed in Year 1 of the Eye Care Technical Framework, and to put that into perspective with regards to a broader picture. Eye care procedures occur within a typical clinical context: a patient has a clinical presentation, and an eye history and physical exam are performed with input by both support staff and eye care professionals. Diagnostic procedures are performed preliminary to, during, and after the history and physical exam by an eye care professional. They may be performed on the same day as the initial history and physical exam, or during another visit.

Healthcare providers may use the terms such as “case,” “encounter,” “appointment” or “visit” to refer to this broader scope. To help avoid confusion with other standards documents and nomenclature, this Appendix introduces the term “Episode of Care”.

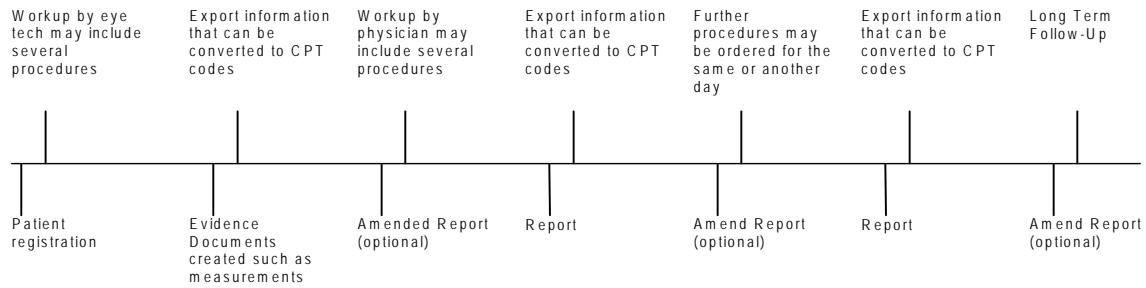

**Figure B-1. Eye CARE Evidence Document Workflow Example**

The clinical activities associated with Eye Care Procedures are shown schematically above. All except “Long-Term Follow Up” and formalizing the creation of the healthcare provider report will be included in year 1. It is expected that some eye care facilities will elect to combine procedures into one study with a single UID, in particular those procedures that have been addressed by combination diagnostic instruments (e.g. keratometry and auto-refraction). Reconciliation of patient demographics in the exceptional event in which a patient’s name has not been added to the modality worklist of the instrument ahead of time (e.g. emergency patient not fully registered, order not created, and failure of DICOM gateway) is also addressed in this Year 2 framework.

Understanding all of the steps in a clinic or practice, how do the steps and actors in an IHE setting both fit and aid in the delivery of excellent and efficient care? As detailed in other parts of this document, there are several actors in the process. Although most healthcare providers aren’t familiar with breaking down their procedures into what may appear to be an artificial number of steps, these actors have specific tasks to perform, any one of which may be taken on by one or more pieces of hardware or software in use within the practice. As an example, consider the order placer.

The job of the order placer is to create a general placeholder of an order, with patient information and possibly a reason for the order. It is the job of the DSS/OF to flesh out the order and to make sure that the information that is generated by the order gets where it needs to go. In human terms in a non-IHE office, when an appointment is made, it is usual on the day of the exam for someone, often at the front desk, to create a basic route slip, which has some patient information on it, and a place to check off what has been done. In some offices, this work is as simple as putting today’s date on the pink slip inside the chart. The front desk person is, in IHE terms, the human that interacts with the Order Placer actor. A technician, who is more trained, could also interact with the Order Placer actor. A healthcare provider could also, though this would be rarer. Most clinics, however, would be very hesitant to have the front desk person start ordering tests based on what a patient said at the front desk. This explains the split between the task of the order

placer and the DSS/OF. Similar scenarios can be used for all of the actors. Let's look at how an IHE run office might work and which pieces of equipment or software might take on which roles.

In the timeline above, a patient calls or shows up at the clinic and is registered. The IHE actor is patient registration. This task can be taken on in a number of places, depending on the information flow and sometimes the size of the facility. The billing software or hospital system is most frequently the patient registration actor. However, many EHR programs have the capability to be the patient registration actor. In some larger institutions, there may be departmental management software, or even very advanced appointment scheduling software that can take on the role. The thing to note is that although multiple points might have the capability to be the patient registration actor, ultimately only one can be the true actor, and the patient registration actor maintains reconciliation between the different access points.

Assuming that the patient has set up an appointment, there are a number of points of access that could act as the order placer. The purpose of the order placer is to create the basic framework that all of the other information for the episode of care will fit within. While it is possible to do a full patient encounter without an order, the reconciliation process that assures that all information gets where it belongs correctly is much more difficult and time consuming. Imagine within a clinical context, a practitioner sees a patient without a chart or a route slip. While it is certainly possible to give excellent care to the patient, getting the record updated later for documentation purposes can be a paperwork nightmare. Working without an order is rightly considered to be an exception and not the rule in the eye care world and is included in Year 2 Technical Framework.

The order placer can be the practice management system or the EHR, even one of the modalities. If properly designed, the order placer can work in conjunction with the DSS/OF to create efficiencies and procedural integrity within the clinic, actually increasing the quality of care. Imagine that the practice management system is acting as an order placer. At the time that the appointment is placed, in a well run practice it is common to get a reason for the visit. When placing the order, this reason, in general terms can be included with the order. The order placer now "knows" that a certain patient is coming in for a certain reason. This is the point at which the DSS/OF takes over.

It is now the job of the DSS/OF to flesh out the details, to handle the assignment of the individual tasks, and to make sure that all tasks are done and that the appropriate access points are updated. Again, this task can be handled by multiple players, but most commonly will be taken on by the EHR. Although it is not a requirement, an EHR vendor might choose to allow the healthcare provider "automatically" to assign a number of tasks, based on the reason for the visit. For example, most practices have a series of steps and tests that is done for every first time patient. The DSS/OF can, potentially, be programmed to create those steps, thus assuring that the steps are done, or at least accounted for. However, the DSS/OF must be able to add other tasks or delete tasks, based on the healthcare provider's determination. The advantages of using the DSS/OF as opposed to the time honored tradition of "yelling for the tech" are the following: it can take less time to create a task in an order than to find the appropriate person, the task can be more exact, and the tracking and notification with regard to the completion of the task are automated, making the healthcare provider's job easier, faster and more effective. That said, this

would probably be the biggest conceptual leap in the process, as it mostly impacts the healthcare provider.

Think of the DSS/OF now as a central intelligence knowing everything that is to be done for the patient during this episode of care. The technician at a piece of equipment can “ask” the DSS/OF what patient is now due (or ready to be imaged) at the station, the equipment now acting as an acquisition modality. Or, the patient might show up in the technician’s room, and the acquisition modality can “ask” the DSS/OF why the patient is there, receiving the task framework for filling in the required information and/or images. The job of the acquisition modality is to provide, ultimately, the healthcare provider with the information needed to take care of the patient. However, this is where the actors might seem artificially differentiated. The acquisition modality actor is not the image manager/archive actor, nor the image display actor, although an equipment manufacturer can choose to do all three. The acquisition modality is responsible for performing the tasks as assigned and maintained by the DSS/OF. When done, the acquisition modality “informs” the DSS/OF, which takes over the processing of the tasks. The DSS/OF sends the information to the image manager/archive actor. This can be the same piece of equipment that acquired the image, an image management application, or even the EHR. The image manager/archive provides access to the images and other data that have been acquired. It is possible to have several access points acting as an image manager, although a strong case could be made for one central repository for efficiency.

The DSS/OF also updates the order status as to the current state of the tasks. An EHR package could take this information and notify the healthcare provider so that he or she would know that the patient was ready for discharge, or for further testing/evaluation. And additional tasks could be ordered either for the current visit, or for the future.

The image viewer actor can be taken on by many access points. Anywhere that the data is needed is a potential place to implement the image viewer, i.e., at the acquiring equipment, within the EHR system, as part of an image management system, even as a stand-alone image viewer. There have even been some recent examples of healthcare providers using an iPod as an image viewer, although software would need to be more thoroughly designed to work well within the IHE framework.

By breaking down the actors to this level of granularity, all of the tasks which must be performed to integrate the information in a well run practice can be defined and then taken on by different vendors. In any practice, through IHE, the process of knowing that all steps have been handled, and the responsible party for each step, is systematized. Ultimately, by using the steps, the clinic achieves the goal of efficiently and smoothly managing a patient episode of care.

## **Appendix C: IHE Integration Statements**

IHE Integration Statements are documents prepared and published by vendors to describe the intended conformance of their products with the IHE Technical Framework. They identify the specific IHE capabilities a given product is designed to support in terms of the key concepts of

IHE: Actors and Integration Profiles (described in Volume I, section 2 of the Technical Framework).

Users familiar with these concepts can use Integration Statements as an aid to determine what level of integration a vendor asserts a product supports with complementary systems and what clinical and operational benefits such integration might provide. Integration Statements are intended to be used in conjunction with statements of conformance to specific standards (e.g. HL7, DICOM, W3C, etc.).

IHE provides a process for vendors to test their implementation of IHE Actors and Integration Profiles. The IHE testing process, culminating in a multi-party interactive testing event called the Connect-a-thon, provides vendors with valuable feedback and provides a baseline indication of the conformance of their implementations. The process is not, however, intended to independently evaluate, or ensure, product compliance. In publishing the results of the Connect-a-thon, and facilitating access to vendors' IHE Integration Statements, IHE and its sponsoring organizations are in no way attesting to the accuracy or validity of any vendor's IHE Integration Statements or any other claims by vendors regarding their products.

**IMPORTANT -- PLEASE UNDERSTAND:** Vendors have sole responsibility for the accuracy and validity of their IHE Integration Statements. Vendors' Integration Statements are made available through IHE simply for consideration by parties seeking information about the integration capabilities of particular products. IHE and its sponsoring organizations have not evaluated or approved any IHE Integration Statement or any related product, and IHE and its sponsoring organizations shall have no liability or responsibility to any party for any claims or damages, whether direct, indirect, incidental or consequential, including but not limited to business interruption and loss of revenue, arising from any use of, or reliance upon, any IHE Integration Statement.

## **C.1 Structure and Content of an IHE Integration Statement**

An IHE Integration Statement for a product shall include:

1. The Vendor Name
2. The Product Name (as used in the commercial context) to which the IHE Integration Statement applies.
3. The Product Version to which the IHE Integration Statement applies.
4. A publication date.
5. The following statement:  
“This product is intended to implement all transactions required in the IHE Technical Framework to support the IHE Integration Profiles, Actors and Options listed below:”
6. A list of IHE Integration Profiles supported by the product and, for each Integration Profile, a list of IHE Actors supported. For each integration profile/actor combination, one or more of the options defined in the IHE Technical Framework

may also be stated. Profiles, Actors and Options shall use the names defined by the IHE Technical Framework Volume I. (Note: The vendor may also elect to indicate the version number of the Technical Framework referenced for each Integration Profile.)

Note that implementation of the integration profile presumes implementation of all required transactions for an actor; options include optional transactions or optional functions for required transactions.

The statement shall also include references and/or Internet links to the following information:

1. The specific internet address (or universal resource locator [URL]) where the vendor's Integration Statements are posted
2. The specific URL where the vendor's standards conformance statements (e.g., HL7, DICOM, etc.) relevant to the IHE transactions implemented by the product are posted.
3. The URL of the IHE Initiative's web page for general information on IHE ([www.rsna.org/IHE](http://www.rsna.org/IHE)).

An IHE Integration Statement is not intended to promote or advertise aspects of a product not directly related to its implementation of IHE capabilities.

## **C.2 Format of an IHE Integration Statement**

Each Integration Statement shall follow the format shown below. Vendors may add a cover page and any necessary additional information in accordance with their product documentation policies.

<b>IHE Integration Statement</b>		<b>Date</b>	12 Oct 2002
<b>Vendor</b>	<b>Product Name</b>	<b>Version</b>	
Any Medical Systems Co.	IntegrateRAD	V2.3	
This product implements all transactions required in the IHE Technical Framework to support the IHE Integration Profiles, Actors and Options listed below:			
<b>Integration Profiles Implemented</b>	<b>Actors Implemented</b>	<b>Options Implemented</b>	
Scheduled Workflow	Image Manager/Image Archive	none	
	Image Display	none	
	Image Creator	Performed Procedure Step	
	Department System Scheduler/Order Filler	PPS Exception Management	
Simple Image and Numeric Report	Report Creator	none	
<b>Internet address for vendor's IHE information:</b> <a href="http://www.anymedicalsystemsco.com/ihe">www.anymedicalsystemsco.com/ihe</a>			
<b>Links to Standards Conformance Statements for the Implementation</b>			
<b>HL7</b>	<a href="http://www.anymedicalsystemsco.com/hl7">www.anymedicalsystemsco.com/hl7</a>		
<b>DICOM</b>	<a href="http://www.anymedicalsystemsco.com/dicom/integrateRAD.pdf">www.anymedicalsystemsco.com/dicom/integrateRAD.pdf</a>		
<b>Links to general information on IHE</b>			
In North America: <a href="http://www.rsna.org/IHE">www.rsna.org/IHE</a>		In Europe: <a href="http://www.ihe-europe.org">www.ihe-europe.org</a>	In Japan: <a href="http://www.jira-net.or.jp/ihe-j">www.jira-net.or.jp/ihe-j</a>

## Appendix D: GLOSSARY

### Terms Specific to this Document

**Actor:** An entity within a use case diagram that can perform an action within a use case diagram.  
Possible actions are creation or consumption of a message

**Evidence Documents:** Evidence Documents represent the non-interpreted information that is primarily managed and used inside the imaging department, although distribution outside the imaging department is not precluded. Evidence documents are non-image information and include things such as measurements, CAD results, procedure logs, etc and are to be encoded as DICOM SR documents or Encapsulated PDF.

**Evidence Objects:** All objects generated as a result of performing procedure steps on systems in an imaging department. These objects are used by the reading healthcare provider in the process of creating a diagnostic report and are managed inside the imaging Department. Examples of evidence objects include: Images, Presentation States, Key Image Notes and Evidence Documents.

**Expected Actions:** Actions which should occur as the result of a trigger event

**Interaction Diagram:** A diagram which depicts data flow and sequencing of events

**Process Flow Diagram:** A graphical illustration of the flow of processes and interactions among the actors involved in a particular example

**Role:** The actions of an actor in a use case.

**Scope:** A brief description of the transaction.

**Trigger Event:** An event such as the reception of a message or completion of a process, which causes another action to occur.

**Use Case:** A graphical depiction of the actors and operation of a system.

### DICOM Terms

**Basic Text SR Storage SOP Class:** See DICOM Supplement 23

**DICOM Model of the Real World:** See DICOM PS 3.3

**DICOM Encapsulated PDF:** See DICOM PS3.3

**Enhanced SR Storage SOP Class:** See DICOM Supplement 23

**Grayscale Softcopy Presentation State Storage SOP Class:** See DICOM PS 3.4

**Grayscale Standard Display Function:** DICOM PS 3.14

**Imaging Service Request:** See DICOM PS 3.3

**Modality:** See DICOM PS 3.3

**Modality Worklist SOP Class:** See DICOM PS 3.4

**Modality Performed Procedure Step:** See DICOM PS 3.3

**Modality Performed Procedure Step Information Module:** See DICOM PS 3.3

**Modality Performed Procedure Step Relationship Module:** See DICOM PS 3.3

**Modality Performed Procedure Step SOP Class:** See DICOM PS 3.4

**N-Event Report:** See DICOM PS 3.7

**Patient:** See DICOM PS 3.3

**Patient Identification Module:** See DICOM PS 3.3

**Print Presentation LUT SOP Class:** See DICOM PS 3.4

**Procedure Plan:** See DICOM PS 3.3

**Procedure Type:** See DICOM PS 3.3

**Protocol Code:** See DICOM PS 3.3

**Requested Procedure:** See DICOM PS 3.3

**Requested Procedure Module:** See DICOM PS 3.3

**Requested Procedure ID:** See DICOM PS 3.3

**Results Information Object Definition:** See DICOM PS 3.3

**Scheduled Procedure Step:** See DICOM PS 3.3

**Scheduled Procedure Step Module:** See DICOM PS 3.3

**Storage Commitment SOP Class:** See DICOM PS 3.4

**Structured Reporting Information Object Definitions:** See DICOM PS 3.3

**Structured Reporting SOP Classes:** See DICOM PS 3.4

**Structured Reporting Templates:** See DICOM PS 3.16

**Unique Identifier (UID):** See DICOM PS 3.5

## **HL7 Terms**

**ADT:** See HL7 version 2.3.1

**Filler:** See HL7 version 2.3.1

**Observation:** See HL7 version 2.3.1

**Placer:** See HL7 version 2.3.1

**Universal Service ID:** See HL7 version 2.3.1

## **Acronyms and Abbreviations**

**AAO:** American Academy of Ophthalmology

**ACC:** American College of Cardiology

**ASE:** American Society of Echocardiography

**EHR:** Eye Care Electronic Health Record System or sometimes called Eye Care Electronic Medical Record System

**HIMSS:** Healthcare Information and Management Systems Society

**HIS:** Hospital Information System

**IHE:** Integrating the Healthcare Enterprise

**IOD:** Information Object Definitions  
**IT:** Information Technology  
**MWL:** Modality Worklist  
**MPPS:** Modality Performed Procedure Step  
**NEMA:** National Electrical Manufacturers Association  
**PACS:** Picture Archive and Communication System  
**PPS:** Performed Procedure Step  
**PMS:** Practice Management System  
**RSNA:** Radiological Society of North America  
**SCU:** Service Class User  
**SCP:** Service Class Provider  
**SPS:** Scheduled Procedure Step  
**SR:** Structured Report  
**UID:** Unique Identifier

## **Appendix E: Security Environment Considerations**

IHE compliant systems usually process private healthcare information. This is subject to national privacy regulations, and possibly other state and contractual requirements. The IHE profiles do not fully define the security mechanisms necessary to protect this information. The ITI-TF Audit Trail and Node Authentication (ATNA) Profile provides one component of this solution.

IHE assumes that actors will be installed on nodes with the following characteristics:

- Each node has a security policy and procedure that applies to its operation. This is assumed to be part of the healthcare enterprise security policy.
- Any user (human, or application process) external to the node boundaries is submitted to an access control procedure in which the user/application will be authenticated.
- All required audit trail events are captured and recorded.

The profiles in this framework assume the following environment:

- Physical Security Environment
  - The equipment is assumed to be located in a physically protected and actively monitored area. This is normally the case with modality equipment because of other patient safety, privacy, and operational concerns. Similarly, the HIS systems and various archives are normally protected. Equipment like PACS workstations are sometimes placed in unprotected areas, but it is usually located where hospital staff monitors and limit access. It assumes that the threat of equipment modification is protected against by means of the physical security mechanisms.
  - The network equipment that connects the computers is also assumed to be physically protected against unauthorized connections and unauthorized modifications. In the

treatment areas of most hospitals the network equipment is in ceilings, cableways, locked cabinets, and other protected areas. There is usually staff present to monitor that no unauthorized activity is taking place.

- Local procedures and operations will be in place to ensure that the physical security assumptions are valid for other areas of the hospital, such as administrative offices, that may be at greater risk.
- Remote locations, especially home offices, are not physically protected. Other means will be used to provide equivalent protection. This may include the use of technology such as VPN connections or HTTPS encryption. Use of encryption or VPN is not a complete replacement for physical security but may be part of an overall protection system.
- The home computer that is used for both personal and professional purposes is difficult to protect. It will be protected from inadvertent modification by malicious software or its use will be prohibited.
- Network Security Environment
  - In addition to the physical security of the network, there will be protection against network access by unsupervised systems. This is typically provided by mechanisms such as firewalls and VPNs.

The threat profile is assumed to be:

- Accidental and inadvertent misuse
- Individual abuse for personal gain, malice, revenge, or curiosity. The abusers are assumed to have only limited access to the underlying systems and software. They are not expert at the internal structure of the systems.
- Random untargeted abuse, such as from an Internet hacker.

The threat profile also assumes that the following threats are either not present or otherwise protected.

- Individual abuse by a system administrator, system developer, or other expert.
- Military or hostile government action
- Organized criminal attack

IHE addresses only those security requirements related to IT systems within the scope of IHE healthcare applications. It does not address security requirements for defending against network attacks, virus infection, etc.

IHE does not mandate the use of encryption because the performance impact of current encryption algorithms is excessive. Most hospital networks provide adequate security through physical and procedural mechanisms. The additional performance penalty for encryption is not justified for these networks. The profiles permit the use of encryption so that it can be used as part of an overall security plan.